

## INTRODUCTION

THE PURPOSE OF A HOUSE PLUMBING SYSTEM IS TWOFOLD. ON THE SUPPLY SIDE, THE IDEA IS TO GET WATER FOR DRINKING, WASHING AND COOKING TO THE APPROPRIATE AREAS OF THE HOUSE. THE WASTE SIDE OF THE PLUMBING SYSTEM GETS RID OF LIQUID AND SOLID WASTE.

THE SUPPLY WATER IS UNDER PRESSURE AND THE WASTE WATER FLOWS BY GRAVITY. SERVICED COMMUNITIES PROVIDE THE FRESH SUPPLY WATER AND CARRY AWAY THE WASTE. IN RURAL PROPERTIES, WELLS, RIVERS OR LAKES SUPPLY FRESH WATER AND SEPTIC SYSTEMS TYPICALLY HANDLE THE WASTE.

THE MAJORITY OF THE PIPING IN A HOME, BOTH SUPPLY AND WASTE, IS CONCEALED IN WALLS, CEILINGS AND UNDERGROUND. LEAKAGE, OBSTRUCTIONS, OR OTHER PROBLEMS MAY NOT BE IDENTIFIED DURING AN INSPECTION.

### 1.0 Supply

#### 1.1 Public Water Supply Systems

Typically, the water mains in residential areas are four inches to 12 inches in diameter, and run several feet below the street level. Smaller pipes, usually 1/2 inch or 3/4 inch diameter, run from city mains into buildings. The water may typically be supplied at a pressure of 40 to 70 psi (pounds per square inch).

**DESCRIPTION** **1.1.1 Water Service Piping:** The 1/2 inch or 3/4 inch diameter service piping carries the water from the street mains to the house. Some early service pipes were 3/8 inch diameter. Most or all of this cannot be seen.

**LEAD** Lead piping was used between the street main and the house up until the 1950s. A good deal of lead supply line is still in use, and many health authorities recommend replacing it. Check the requirements in your area. If the water has not been run for some time, many recommend that the water be run for several minutes before using it. The life expectancy of lead piping is indefinite.

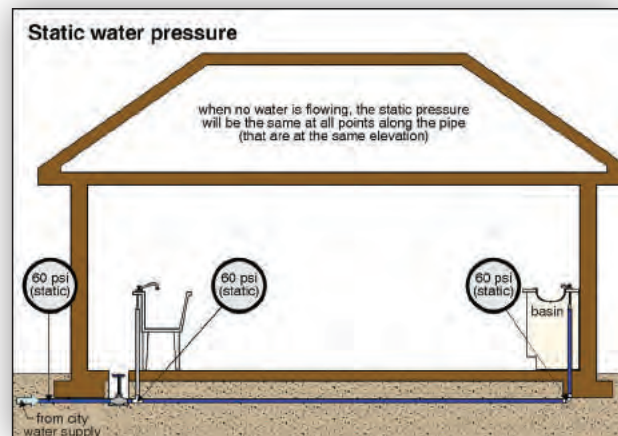

- COPPER** Copper piping has been used extensively since the early 1950s for supply lines from the city main to the house. From 1950 to 1970, 1/2-inch diameter piping was used commonly. After 1970, 3/4-inch diameter copper service piping has been common. The life expectancy of copper piping is dependent on water conditions. In many areas, its life expectancy is indefinite. In harsh water or soil conditions, it may fail within 20 years.
- GALVANIZED STEEL** Galvanized steel is not commonly used as a service pipe, although galvanized steel fittings may be found at the point of entry into the house. Where galvanized service piping is used, it is typically at least 1 1/4-inch diameter. The word **galvanized** means zinc-coated. The coating helps prevent the steel from rusting.
- PLASTIC PIPING AND TUBING** Plastic water service piping may be polybutylene (PB), polyethylene (PE), cross-linked polyethylene (PEX), polyvinyl chloride (PVC) or chlorinated polyvinyl chloride (CPVC). Most plastic piping is buried at least 18 inches deep. Exposed piping may be subject to mechanical damage and deterioration from sunlight.

### Common Problems with Water Service Piping

- LEAKS** Since the supply line from the street cannot be seen, no comment is offered during a home inspection. If there is a leak, it may go undetected for some time. In some cases, water can be heard running outside the basement wall. Water accumulating in the basement or a wet spot on the lawn is often the first indication. Leaks may be caused by building settlement, excavation, poor connections, faulty valves or a flaw in the pipe itself.
- The underground water service line from the property line to the house is owned by the homeowner. Beyond the property line, the pipe is the responsibility of the city. A leak in the pipe requires excavation, and it is often difficult to know whether the leak is on the city's or the homeowner's side. The city is usually contacted and they excavate their section of the pipe, correcting the problem if they discover it. If no problem is found, the homeowner is left to correct the problem on his or her own. In some cases, the homeowner must pay for the city's work if the city pipe is not at fault. Some municipalities use sophisticated leak detection equipment.
- LOW PRESSURE** Poor water pressure in the house may be the result of a partially closed or obstructed valve in the street. It may also be because of blockage, such as a stone or other foreign body in the pipe.
- New piping may be crimped during installation or become pinched under a rock during back-filling operations. This can also cause low water pressure.

City water mains may be undersized or deteriorated in older neighborhoods. Some cities have poor pumping and/or distribution systems. In these cases, low water pressure problems are usually experienced at every home in the neighborhood. The solution is to petition the city to improve its system.

**SMALL** In most new housing, the supply pipe from the street to the house is 3/4-inch diameter. In older houses, the piping was as small as 3/8-inch. Modern life styles and additional plumbing fixtures usually require a larger line, capable of providing more pressure and volume. Replacing this pipe is an expensive and disruptive job. It is often deferred as long as possible.

**SHARED** In some older semi-detached (attached) and row houses, a single supply line would run under a front lawn, and then split to feed two houses. This often yields unsatisfactory water pressure for both houses and is often replaced with two larger, separate lines.

**PRESSURE REGULATOR NEEDED** Where municipal water pressure is above 80 psi, a regulator should be provided to reduce the in-house pressure to prevent leaks at fixtures, stress on appliance hoses and possible broken pipe joints.

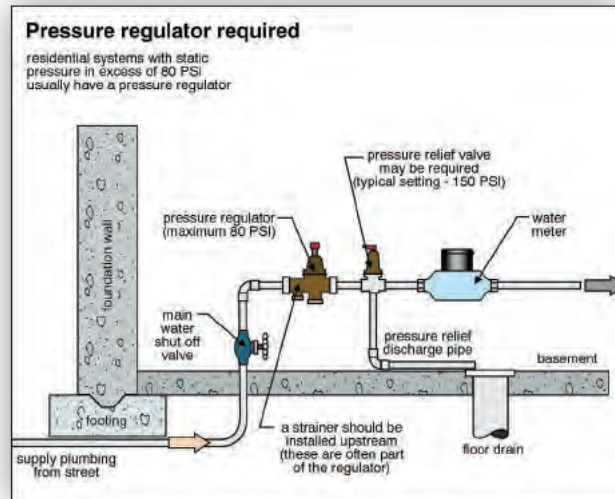
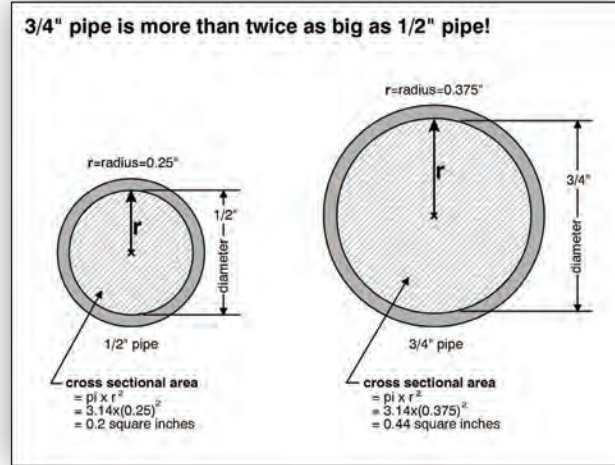

**RISK OF FREEZING** It is unusual, although not impossible, for the service pipe to be too close to the surface, and to freeze during very cold weather. Many service pipes extend above grade just before they enter the house. Freezing is a risk here in cold climates.

**LEAD** Up until World War II, most of the service pipes in built-up areas were lead. While these generally provide good service, they are small in diameter and may have to be replaced. Also, lead is relatively soft, and if building settlement occurs, there is a chance of leakage or crimping the pipe. Leaks can also occur at connections as a result of long-term deterioration.

**STEEL NIPPLE NEAR END OF LIFE** Many of the old lead service lines were connected to a galvanized nipple – a short piece of steel pipe that was often in contact with the soil. This pipe rusts on the outside and inside, and may be close to the end of its life. It is often wise to replace this as a precautionary measure. Galvanized steel service pipes typically last roughly 40 years.

## 1.2 Private Water Supply Systems

**DESCRIPTION** Where a city water supply is not available, water is provided from a well, river or lake. Wells may be shallow (25 feet or less) or deep (more than 25 feet). The service piping is most often plastic (commonly polyethylene).

**PUMP** A pump moves the water from the source into the house distribution piping system. The pump may be at the bottom or top of a well, in a pump house, in the river or lake, or in the home.

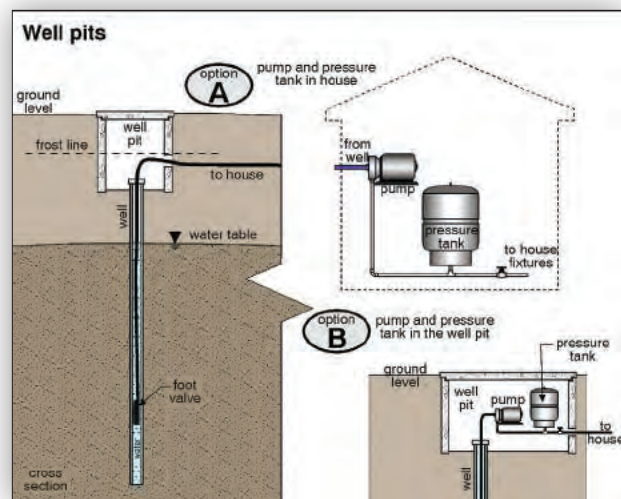

Reciprocating or piston-type lift pumps were used on older systems, while centrifugal pumps are more typical in modern installations. Shallow wells may use reciprocating or centrifugal pumps. Deep well pumps are most often centrifugal, either jet type or submersible.

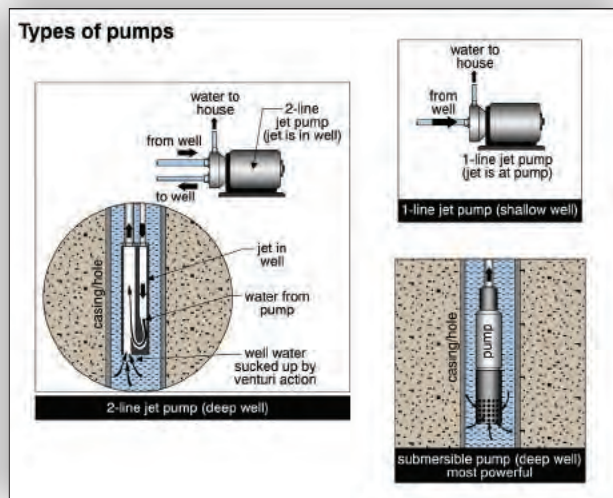
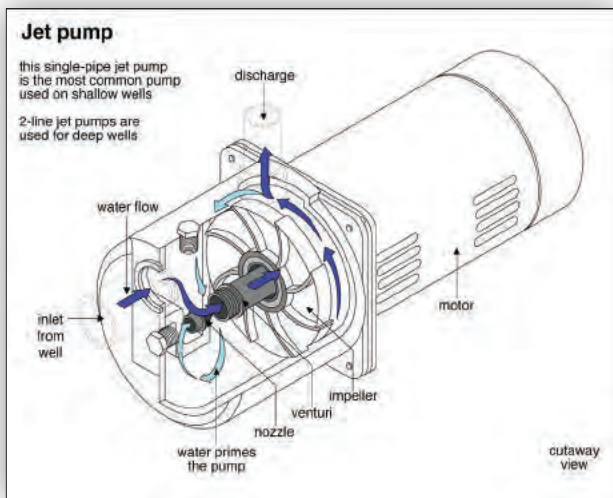
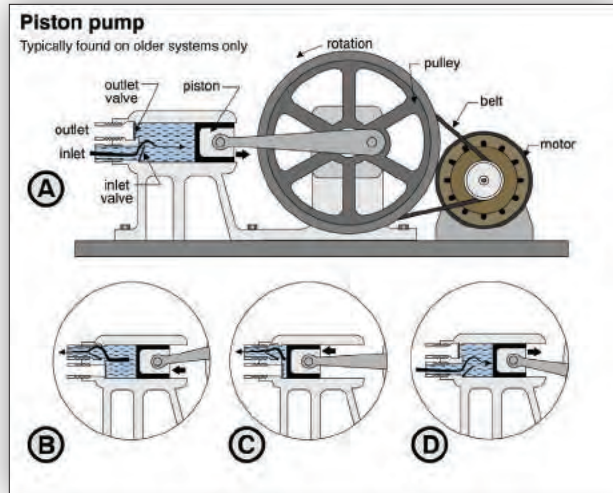

Well water should be tested on a regular basis, as recommended by the local health authorities. Typically, this involves sending a sample to the authority for testing.

The amount of water available from the well depends on the amount of water in the well and the recovery rate of the well. If water is drawn from the well faster than it is replenished, the well will eventually run dry. Many homeowners with wells manage their water demand to avoid depleting the well. The water supply may vary season-to-season and year-to-year.

**PRESSURE TANK** Where a pump is used, there is also a storage or pressure tank, typically located in the home. This tank provides an air cushion, so the pump does not have to come on every time a faucet is opened. This tank may be only a gallon or two, or it may be several gallons. The tank provides relatively even water pressure to the house. With no tank the water pressure in the home would vary quickly and dramatically, and the pump would cycle on and off frequently.

Since water is relatively incompressible, a portion of the tank is filled with air. The air is easily compressed, and when a valve is opened, the air pressure in the tank forces the water out. The tank pressure slowly reduces as the water leaves and the air expands. When the pressure gets low, the pump pushes more water into the tank, compressing the air. Typical low and high limit settings for a pump are 30 psi and 50 psi.

Many modern tanks have a diaphragm or bladder separating the air and water, preventing the air from being dissolved into the water.

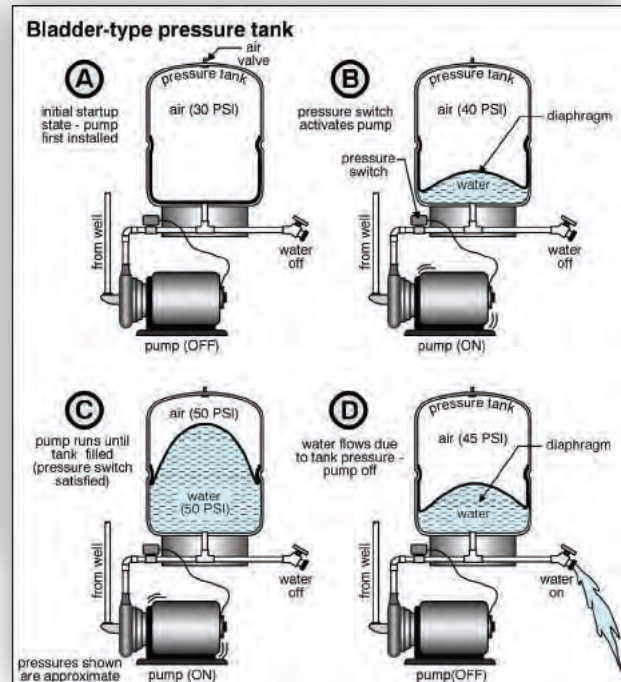
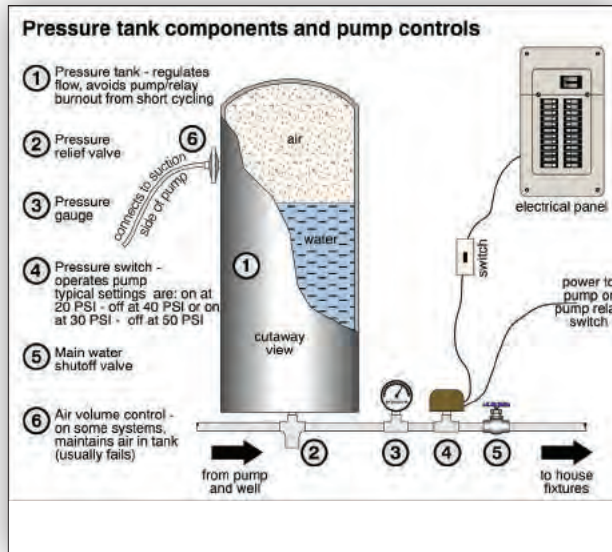

**WATERLOGGED** Over time, the air in the tank will be absorbed into the water and the tank will become ‘waterlogged’. This means that the tank is full or nearly full of water. The pump will come on and off very quickly. This short cycling is hard on the pump, and air is added to the tank to correct the situation.

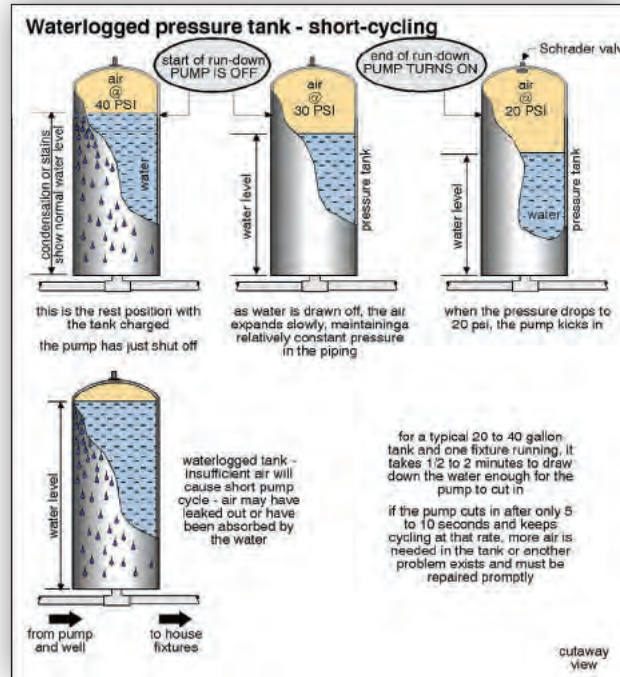

## Common Problems with Private Water Supplies

**PUMP PROBLEMS** Inoperative supply pumps may be the result of a mechanical or electrical problem. Poor water pressure may be the result of a partially closed valve, an obstructed pipe, a leak in the system, or poor adjustment of pressure switches.

A pump may short-cycle or run continuously if the foot valve is leaking, the pressure tank is waterlogged, the pump has lost its prime, or if the pressure switch is faulty. This may also be the result of a leak in the plumbing system.

Worn pump bearings or poor alignment can result in excessive noise or vibration.

**WATER SUPPLY PROBLEMS** If the well is close to running dry, the water may be dirty. Alternatives are to reduce water use (stop watering the lawn, for example) or improve the water supply.

**LEAKS** Leaks may occur at the pump or piping.

**LEAKING TANK** The pressure tank is susceptible to corrosion and/or leakage. Condensation on the outside of the tank, common in hot humid weather, can rust the tank. Ideally, the tanks are insulated to minimize condensation, although very few are. A corroded tank is replaced when it begins to leak. A leak caused by a poor connection is easily repaired.

### 1.3 Main Shut-off Valve

**DESCRIPTION** The main shut-off valve controls all the house water. The valve should be readily accessible and easy to operate. Since these valves are not used regularly, it is common for them to be stiff. They often leak when operated. For this reason, they are not tested during a home inspection.

Some main shut-off valves have bleed valves to drain the system once the valve is closed. Some of these bleed valves can be shut off, although others discharge automatically, as the main valve is closed. This discharge of water can be disconcerting if one is not familiar with the bleed valve function.

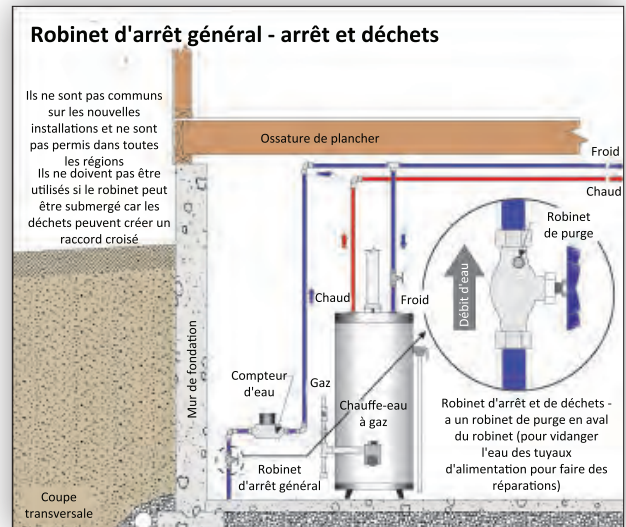

#### Common Problems with Main Shut-off Valves

- MISSING/** These valves should be accessible and operable to shut off the water in an emergency
- DAMAGED/** to avoid flooding damage. Missing shutoff valves should be provided. Damaged or leaking
- LEAKING/** valves should be repaired or replaced.
- INACCESSIBLE/**
- INOPERABLE**
- PARTLY CLOSED** Poor water pressure may be the result of partially closed valves. This, of course, is easily corrected.

### 1.4 Water Distribution Piping in House

Only a small section of the distribution (supply) piping can be seen during a typical home inspection.

**DESCRIPTION** **1.4.1 Galvanized Steel:** Galvanized steel piping was common until roughly 1950. This piping typically lasts 40 to 60 years. Some lower-quality pipes do not last as long and there are some oversized pipes still in use after 60 years. Where it is found today in single-family homes, it is usually near the end of its life.



Galvanized steel supply pipes are typically 1/2-inch diameter. The connections are threaded. When the pipe corrodes, the rust accumulation inside the pipe chokes down the diameter of the pipe, resulting in poor water pressure. Rust also attacks the pipe walls, making the walls thinner. Eventually, the pipe will rust through, usually at the joints first, resulting in leakage.

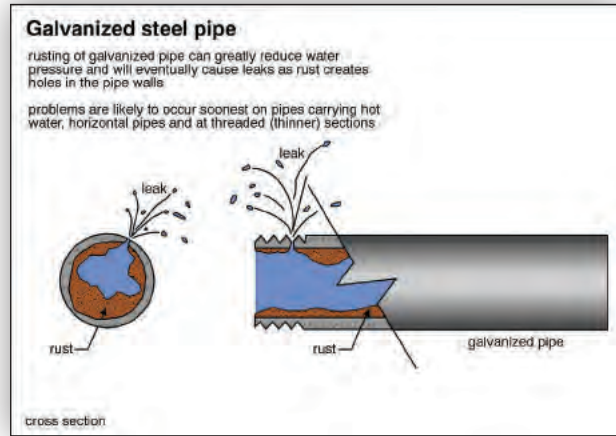

**RUST** As rust builds up inside the pipe, a brownish color is often noted in the water when a faucet is turned on, especially after several days of inactivity. This rust in the water usually dissipates after a few seconds.

**DESCRIPTION** **1.4.2 Copper Pipes and Tubing:** Copper pipes have been in use residentially since approximately 1950.

**LIFE EXPECTANCY** Copper piping is typically 1/2 or 3/4 inch diameter. Copper piping will last indefinitely, unless there are corrosive water conditions or manufacturing defects. Copper piping has soldered connections and the walls of the pipe are thinner than galvanized steel.

**FLEXIBLE TUBING** Flexible copper tubing can be bent around corners using special tools. This is not common since it is more expensive and can be awkward to work with in close quarters.

**DESCRIPTION** **1.4.3 Plastic Pipes and Tubing:** Plastic supply piping is popular because it is less expensive and easier to work with than copper. Connections can be made without soldering, and the pipe is easy to work with. There are many types available including cross-linked polyethylene (PEX), polybutylene (PB), and chlorinated polyvinyl chloride (CPVC).

**CROSS-LINKED POLYETHYLENE (PEX) AND POLYBUTYLENE (PB)** PEX and PB pipe use mechanical fittings (crimp and compression type). Care must be taken that the pipe does not contact heating ducts. If the pipe freezes, it is less likely to burst than copper piping. The pipe tends to sag and should be well supported by hangers. PEX should not be installed outdoors or exposed to sunlight for long periods. Polybutylene piping has been the source of considerable controversy due to failed fittings, especially first generation plastic fittings.

**CPVC** Chlorinated polyvinyl chloride (CPVC) pipe is not as flexible as PB or PEX and the fittings are solvent welded (glued) rather than press-on. This pipe is likely to split if freezing occurs. CPVC pipe is suitable for use on both hot and cold water lines.

Many plumbers prefer to work with copper and, although plastic pipe is less expensive than copper, the fittings are expensive. Some areas do not allow plastic pipes based on environmental concerns. Some questions have been raised about the chemicals used in the adhesives used to join sections of piping, and the toxic gases given off from plastic piping during a fire.

Polyethylene (PE) and polyvinyl chloride (PVC) are only suitable for waste, underground water service pipes or cold water piping systems.

### Common Problems with Distribution Piping

**FLOW (PRESSURE)** People like to have lots of water flow and pressure at faucets. Water flow (in gallons per minute) is a function of several things, including the size and shape of the faucet opening, and the pressure at the faucet. The pressure at the faucet is a function of the pressure available from the source, and the pressure lost moving the water through the pipe to the faucet. Typically, city water supplies are at 40 to 70 psi (static pressure). **Psi** means **Pounds per square inch**, and is a common way of measuring water pressure. Pressure loss in the home is due to elevation (we lose pressure when we push water up from one story to the next) and friction as water flows through piping. Larger pipes lose less pressure due to friction.

**PRESSURE VS. FLOW** Static pressure is exerted by the water against the pipe walls with no water flowing. Here's a simplified (and not 100% accurate) way to look at it. A 100-foot long horizontal pipe connected to a 60 psi supply will have a pressure of 60 psi anywhere along the pipe, with no flow. As water begins to flow, the pressure drops. This is a result of friction loss along the pipe walls. If gauges were put on the pipe every ten feet, the gauge at the source would still read 60 psi, and (depending on the pipe diameter and the amount of water flowing), the gauge ten feet from the source might read 58 psi; the gauge twenty feet down would read 56 psi, the next gauge 54 psi, etc. At the faucet, the pressure might be 40 psi.

As the flow increases, the pressure drops more at each point along the pipe. The water pressure at the source (city water main) will remain at 60 psi. The amount of pressure lost due to friction as water flows depends on the pipe diameter and the amount of water flowing. With several faucets open, the flow at each faucet may be weak and there may not be enough pressure for a shower, for example.

**IMPROVEMENT APPROACH** As more plumbing fixtures flow, the pressure and flow drops more at each fixture. If we replace any ten-foot section of pipe with a larger pipe, the pressure drop across that section will be reduced. Replacing any section of pipe improves pressure (and flow) throughout the system.

**GRAVITY PROBLEM** Gravity is another source of pressure loss. Energy is required to push the water uphill. For every one foot we push water uphill, we lose 0.434 psi. Another way of saying this is that it takes one psi to move water up 2.31 feet. A system will typically lose eight psi in a two-story house, getting the water from the basement up to the second floor bathroom. With no water flowing, the static pressure at the street main may be 60 psi, but the static pressure at the second floor basin might be 51 psi. Houses that are above the street or have third story plumbing fixtures, have a pressure disadvantage.

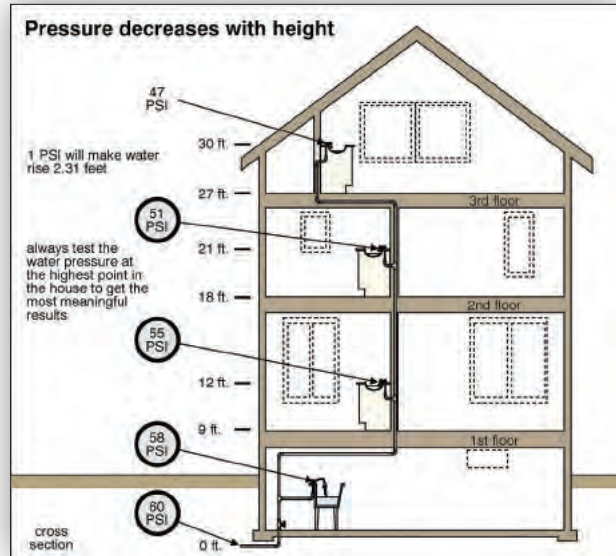

**GALVANIZED STEEL FAILURE** Galvanized steel piping will often leak first at the joints. Steel pipe has threads cut into it where it joins a fitting. The pipe wall is thinner at the threaded connections. As the piping rusts from the inside, the pipe rusts through first at the threaded connections, where the pipe wall is thinner. We saw this in the illustration on Page 298.

As steel piping corrodes, it may rust through at one spot and begin to leak; however, the rust may form a scab over the leak and the leak may be intermittent as the rust progresses. This scabbing means the pipe is close to the end of its life, even though it may not be actively leaking.

Poor pressure and flow may be noted before the pipe leaks. The rust inside reduces the diameter, restricting flow.

**OTHER REASONS FOR POOR PRESSURE OR FLOW** The main shut-off valve or isolating valves may be partially closed or obstructed. The city valve near the property line may restrict flow. The supply line from the street to the house may be undersized, damaged or leaking. Long runs of relatively small (1/2-inch diameter) pipe result in considerable pressure drop, especially with more than one fixture flowing. Solutions include replacement with larger pipe or shortening the runs.

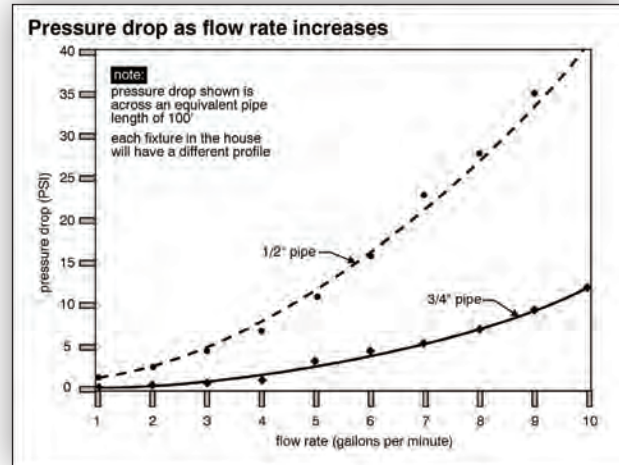

Sludge build-up in a water heater can lead to poor hot water pressure. The tank should be flushed every year or so. A water softener, especially if not well maintained, can adversely affect water pressure.

Adding plumbing fixtures (a new bathroom, for example) without enlarging or adding pipes often leads to pressure complaints.

A crimped, damaged or clogged pipe within the house will adversely affect pressure. This is common with amateurish work. On a private system, a defective, undersized or poorly adjusted pump will result in poor pressure. Individual faucets may also be defective.

**LEAKS** Leaking supply pipes can range from an annoying drip to a major flood. In most cases, however, leakage appears first as a drip. This can usually be picked up before serious flooding occurs.

**CONNECTIONS** Leakage as a result of a poor connection is impossible to anticipate, and may be caused by vibration over a period of time. If a connection lets go suddenly, there will be a flood.

**DAMAGE** Mechanical damage will sometimes result in a leak immediately, although in other cases a joint is simply weakened and subsequent vibration will cause the leak sometime later. Concealed piping may be damaged by drilling or nailing into walls.

**FREEZING** Leakage can be a result of pipes freezing. A one-time freeze may not result in leakage. In some cases, copper piping may develop a bulge, although the piping may not split on the first freeze. Frozen pipes, of course, do not leak until there is a thaw. Some types of plastic supply pipe have better resistance to freezing damage than copper.

It is easy to see how pipes can freeze if they are installed in an unheated area such as a garage or crawl space. Pipes inside the house that have been in place for 50 years may freeze if they are cut off from their heat source when adding insulation to walls, for example. Supply piping on exterior walls is always vulnerable to freezing.

In an old house, pipes running up to a kitchen sink may not have frozen in the past simply because the air under the sink circulated freely and kept the pipes warm. If the kitchen is remodeled, and a closed cabinet is provided under the sink, the same pipes may now freeze since they are cut off from the warm circulating air.

**SWEATING (CONDENSATION)** In some homes, the cold water piping is insulated to avoid sweating of pipes. On a warm humid day, cold water running through a pipe will cool the adjacent air, causing condensation on the pipes. This 'sweating' can be annoying, and if allowed to continue, can damage ceilings, floors, furniture or storage below. If a basement is to be finished, the cold water piping above the ceiling should be insulated.

**NOISE** Noisy piping is usually the result of inadequately secured pipes. When pipes are not well secured where they run through floors walls and ceilings, they may be noisy.

As valves are opened and closed, vibration can be set up in the piping making it rattle. Sometimes this can be corrected by pushing newspapers into the wall cavity to keep the pipes from contacting the walls or each other. Foam insulation can also help in some cases. Where a pipe passes through the floor system or wood studs, it may rub on the wood and squeak as the pipe expands and contracts with heat.

**WATER HAMMER** Water hammer (or hydrostatic shock) is a noisy pipe problem that occurs when valves are shut off quickly. Water hammer can damage pipe connections and result in leakage.

Water hammer works like this: water passing through a pipe has momentum. When the valve is shut quickly, the momentum of the water carries it into the valve with considerable force. Since water is essentially incompressible, a large pressure is built up against the valve, and there is low pressure upstream in the pipe. The high-pressure water wants to flow to the low-pressure area. This happens so quickly that a small vacuum is created against the valve as the water moves away from it. This can result in cavitation as the water is pulled back against the valve a second time. This continues back and forth in slowly diminishing shock waves. Pressures up to 600 psi can result from water travelling up to 3,000 miles per hour, for very short periods.

Water hammer can result in loud noises in supply plumbing pipes. Water hammer only occurs as valves are closed. If a valve is closed slowly, and the noise does not occur, one can be sure that water hammer is the problem. Water hammer is common with quick-closing electrically operated valves on appliances such as washing machines and dishwashers.

Air chambers can be installed to control water hammer.

**EXPOSED TO DAMAGE** Pipes or tubing that are exposed below a basement ceiling or surface mounted on walls are easily damaged. Pipes should never be located so that they can be struck by a door, or be pushed out of position by storage. Wood blocks can be run beside pipes to protect them from damage.

**INADEQUATE HANGERS** All piping and tubing should be adequately supported with hangers. Copper piping should not be supported with steel hangers because of the corrosion that will take place. Copper pipes should not contact heating ducts for similar reasons. Plastic piping and tubing should be well supported and be kept away from heat ducts.

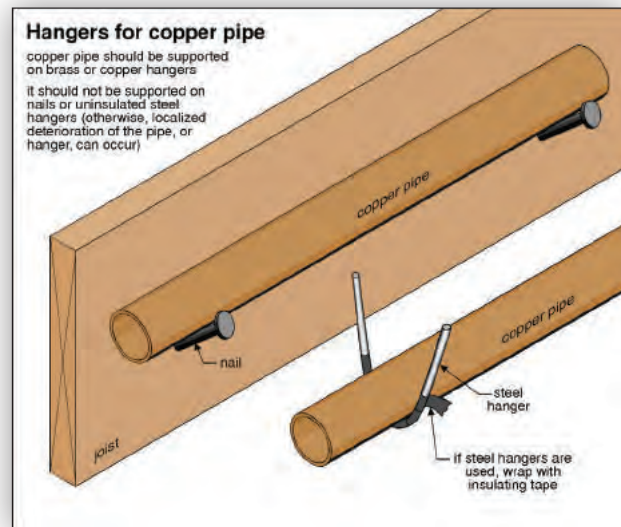
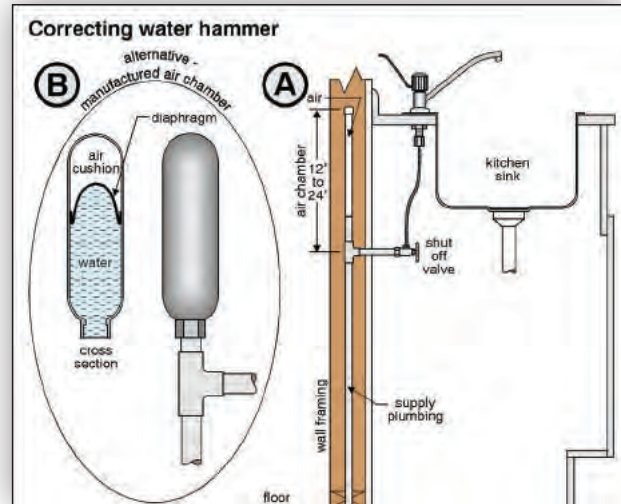

**POLYBUTYLENE LEAKAGE ISSUES** There has been a great deal of publicity in various parts of North America regarding leakage problems with polybutylene plumbing supply lines, including class action lawsuits.

**PLASTIC FITTING FAILURES** The majority of leak problems with polybutylene supply lines involve failure of plastic (acetal) fittings. Fitting failure may lead to the need for system replacement. This type of fitting was commonly used from the late 1970s until the late 1980s. Copper fittings were used in most installations from the late 1980s until the late 1990s. Failure of copper fittings is rare. Failure of the actual polybutylene piping also seems relatively uncommon.

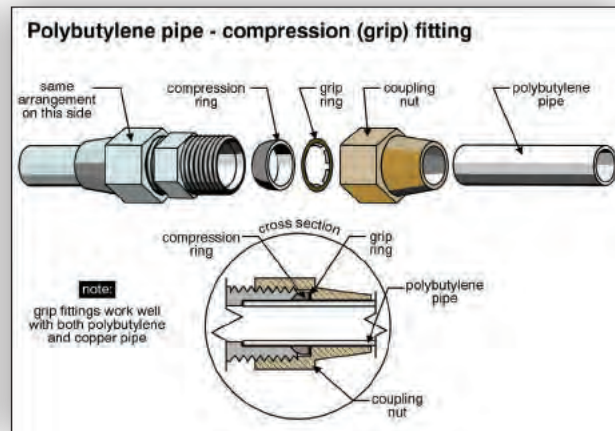
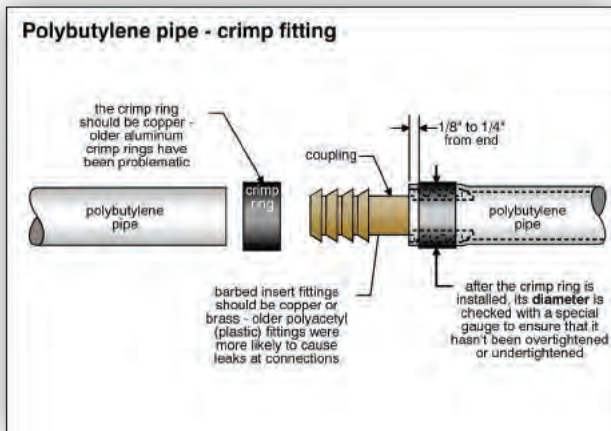

**CROSS CONNECTIONS** A cross connection is a dangerous situation where waste water may enter and contaminate the supply water. A cross connection can occur in many places. One example is where a laundry tub has a faucet below the top of the laundry tub. If the faucet enters the tub through the wall, it is possible that when the tub is filled, the faucet will be submerged. If this happens, the waste water in the tub may back up into the drinking water through the faucet if the supply piping is being drained.

The solution is to raise the faucets above the top of a tub or basin, creating an air gap between the faucet and water in the tub. Cross connections are avoided through the use of an overflow. In bathtubs, for example, where the faucets may enter through the wall of the tub below the top, an overflow provided below the faucets will prevent a cross connection.

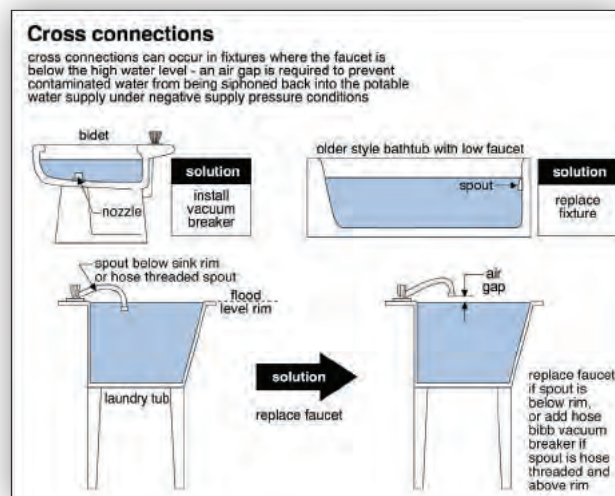

**BIDET IS ACCEPTABLE** Some plumbing fixtures necessarily create a situation which could lead to a cross connection. A bidet is a good example of this. A bidet has a water supply at the bottom of the bowl. This allows water to be directed up in a spray from the bottom center of the bowl. There is, of course, the potential for waste water in the bowl to get into this supply water. A special device (vacuum breaker) prevents water from flowing back into the supply plumbing.

**GARDEN HOSE – CROSS CONNECTION** While cross connections are normally avoided during original plumbing work, home handy man changes can create them. Careless use of the house plumbing system can also create a cross connection. Care should be taken, for example, to avoid placing a garden hose in a position to allow waste water to flow back into the supply plumbing system. For example, if the hose is left in a pail of water, it is possible for the contaminated water to flow back through the hose into the drinking water. This may happen if the house water supply is shut off and partially drained for some reason, while the hose is in the pail. Back-flow preventers (like the atmospheric vacuum breaker in the illustration) on the hose bib can prevent this.

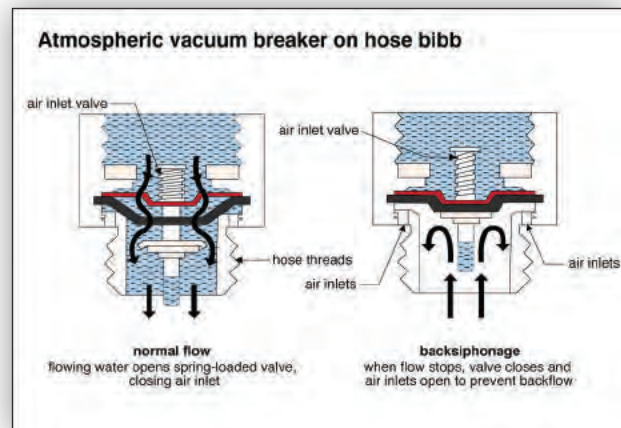
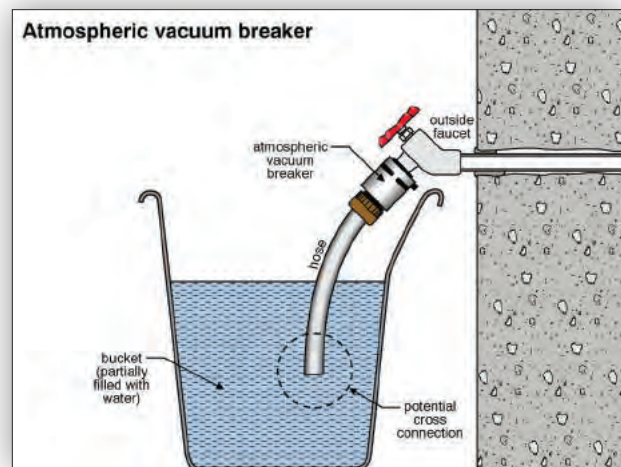
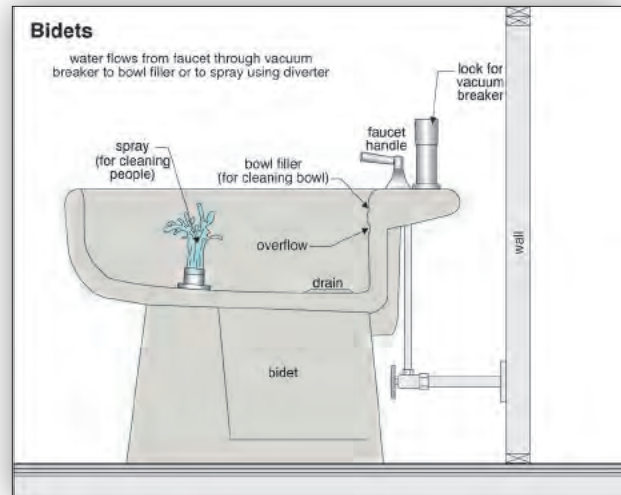



**BOILER CROSS CONNECTION** On hot water heating systems, the plumbing is connected to the boiler so that water can be added to the boiler. Modern installations have a back-flow preventer to prevent the boiler water from coming back into the drinking water. This is another potential cross connection. Older systems may not have back-flow preventers to protect against this.

**INAPPROPRIATE/ LOW QUALITY MATERIALS** Many materials used for supply plumbing were not intended for this use, and may be expected to have a short and troublesome life. These materials include rubber hoses, garden hoses, and non-certified plastic piping. Polyvinyl chloride (PVC) and polyethylene (PE), for example, should not be used as hot water piping. Connections made with the wrong materials or wrong devices cannot be expected to perform properly. Special connectors are provided for special types of piping.

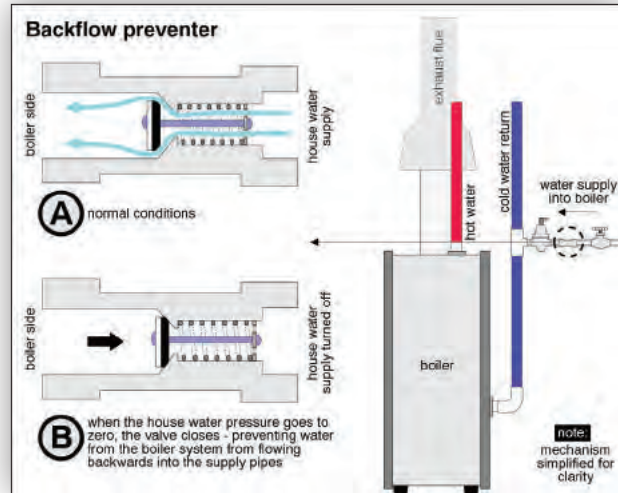

### 1.5 Isolating Valves

**DESCRIPTION** Isolating valves allow someone to work on a part of the plumbing system without shutting off the entire house water supply. Almost every toilet has an isolating valve, and there should always be an isolating valve on the cold water supply to the water heater. High quality installations have isolating valves on every set of risers running up from the basement and isolating valves under each sink and basin.

#### Common Problems with Isolating Valves

**LEAK** The most common problem experienced with isolating valves is leakage through the valve connection, packing or washer.

**INOPERATIVE** Inoperative valves are often not noted until there is an emergency. Many toilet isolating valves become stuck, and are therefore useless. Replacing the isolating valve is not a large expense. If an isolating valve does not turn with normal effort by hand pressure, a wrench should not be used unless one is prepared to shut off the main supply valve very quickly if the valve is damaged. Sometimes forcing a valve will result in leaking when the valve is re-opened.

Isolating valves are not operated by home inspectors due to the risk of leakage.

## 1.6 Water Heaters

**DESCRIPTION** Domestic water heaters provide hot water to the faucets and appliances. Most water heaters are conventional storage-type heaters, where heated water is stored in a large tank. There are also tankless systems, where water is heated on demand, either by a boiler, or a dedicated water heater. Indirect water heaters are a third type. They typically have a large tank, with the heat being provided by the boiler that heats the house.

Water may be heated by gas, propane, oil or electricity. Solar water heaters are also available.

Water heaters may be used to heat all, or part of a house, through the use of fan-coil units, or radiant heating. This is called a combination heating system because the water heater provides domestic hot water and it heats the home.

**OPERATION** **1.6.1 Conventional Water Heaters:** Whether heated by gas, propane, oil or electricity, all conventional water heaters work the same way. Cold water enters the tank, and heated water leaves the tank. The heated water temperature is typically 120 to 140° F. When a fixture runs

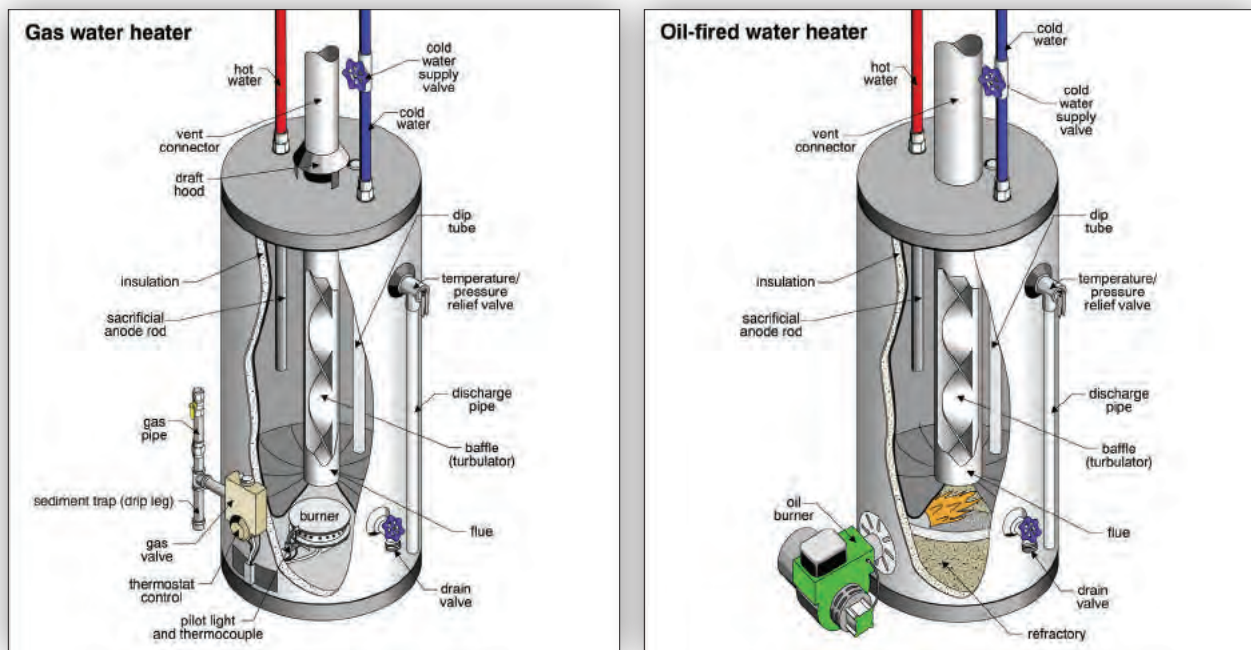

hot water, the heated water leaves the tank and cold water enters, triggering the thermostat and turning on the burner or element. If heated water flows out faster than the incoming cool water can be heated, we will run out of hot water. The larger the tank, the longer it takes to run out of hot water.

**SIZE** Water heaters should be big enough to satisfy the needs of the house. A family of four will often find a 30-gallon gas or oil system or a 40-gallon electric heating system satisfactory.

**RECOVERY RATE** When the hot water is depleted, the recovery rate becomes important. Generally speaking, oil has the fastest rate of recovery, with gas second and electricity third. If water is drawn off slowly, the recovery rate may be such that the tank can be kept filled with hot water. Faster recovery rates allow more water to be drawn off without running out of hot water.

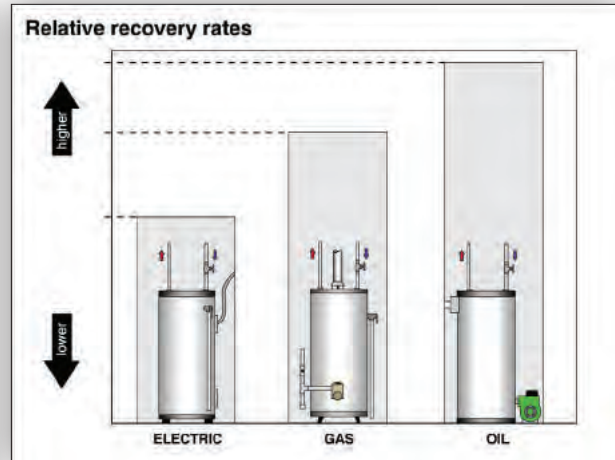
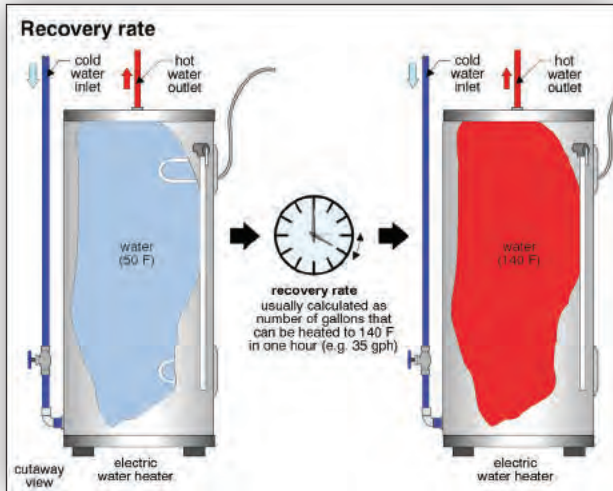
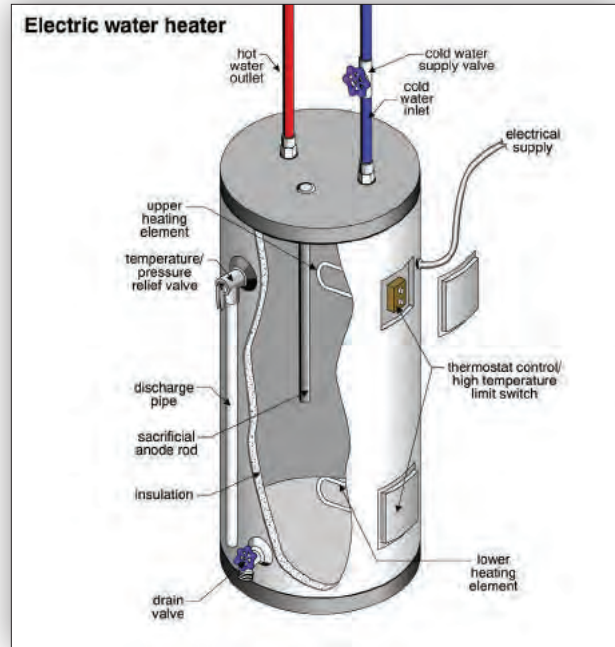

- INSULATION** The tanks are insulated to slow the heat loss from the tank. Energy-efficient tanks have better insulation. Some people also insulate their hot water piping.
- TEMPERATURE SETTINGS** Thermostats control the water temperature. There are some conflicting issues around appropriate water temperature. We don't want the water so hot that it scalds people, but we want it hot enough to prevent bacteria like Legionnaires disease from growing in the water heater. Also, dishwasher manufacturers often recommend that the water be 140° F, since some dishwashing detergents will not dissolve completely at lower temperatures. Many dishwashers have internal heaters to bring cooler water up to appropriate temperatures for washing dishes.
- MIXING VALVES (TEMPERING VALVES)** Some jurisdictions require tempering valves on water heaters, so water in the tank is at 140°, but as it leaves the tank, cold water is mixed in to deliver 115° to 120° water. These tempering valves may be installed at the water heater, or at individual fixtures.

### Common Problems with Conventional Water Heaters

- FUEL PROBLEMS** Malfunctioning burners, electric elements, sensors or controls will cause poor operation or may result in the system not working at all, meaning no hot water. Please see the Heating chapter for more information about fuel systems, burners and electric elements.

- EXHAUST VENTING ISSUES** Most gas and oil water heaters have to be vented into a chimney with adequate draft. Poorly arranged or disconnected vents are safety hazards, which should be corrected promptly. Aluminum vents are not permitted. Vent sections should be as short as possible, screwed together, and should slope up 1/4 inch per foot, minimum. Vents should extend two feet above the roof and should be two feet above anything within ten feet horizontally. Vents should extend at least five feet

above the draft hood. Exhaust gases spilling out at the draft hood or burner may present a life-threatening situation. This problem requires immediate action. Some modern gas water heaters employ induced draft fans and high-temperature plastic venting that discharges out through the house wall. The vent materials were originally PVC, CPVC or ABS. In some areas these are replaced with special plastic vent pipes rated for the high exhaust gas temperatures.

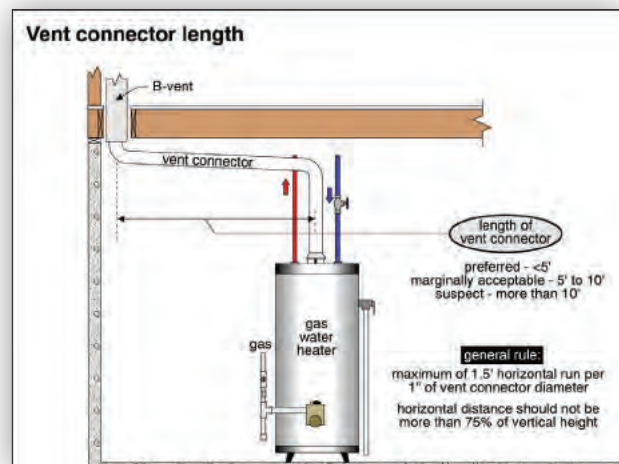

**POOR LOCATION** Gas or oil water heaters should not be in sleeping areas. This is a safety issue. Gas-fired heaters in garages should be 18 inches above floor level to reduce the risk of the heater igniting gasoline fumes, and should be protected from mechanical damage. Some jurisdictions call for electric heaters in garages to be similarly elevated.

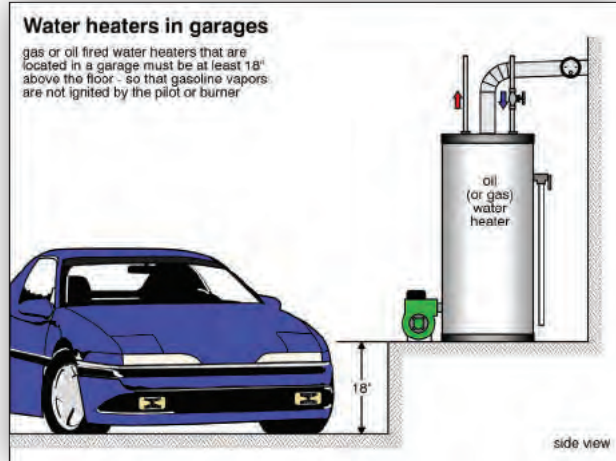

**FAILED ELECTRIC ELEMENTS** It is not unusual to find one of the two elements in electric water heaters burned out. Replacing an element is not expensive. Most heaters are arranged so that both elements cannot be on at the same time – the elements operate in a sequence. Depending on which element fails, there may be some hot water, or none.

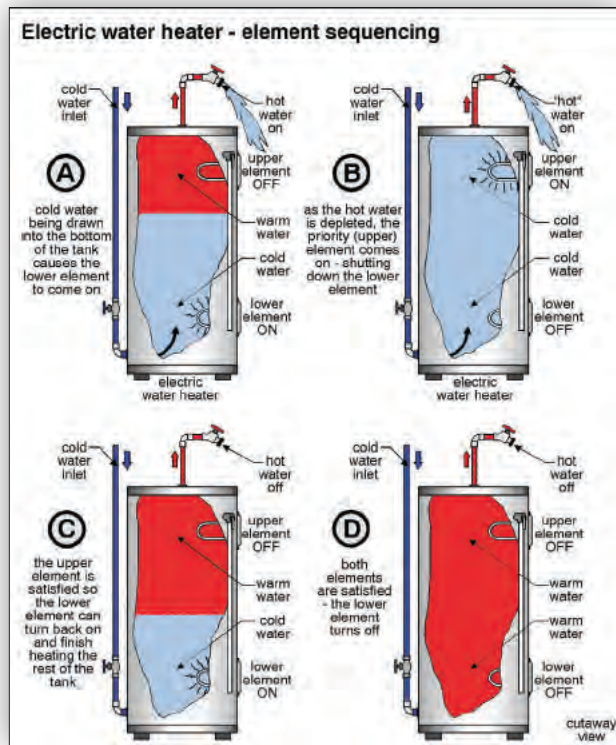

**LEAK/DAMAGE** Water heaters can, of course, leak, and the tanks can be mechanically damaged.

**SLUDGE** Where sludge has accumulated in the bottom of the tank, water pressure from the hot water system may be limited. When water pressure problems are experienced on the hot water system only, it makes sense to drain the water heater to ensure that sludge accumulation is not the problem. Some experts recommend draining one or two gallons out of the bottom of the tank monthly to prevent sludge build-up.

**RELIEF VALVE UNSAFE** The temperature/pressure relief (TP or TPR) valve lets water escape if the temperature or pressure is too high. This valve should be connected to a tube that discharges no more than six inches above floor level so hot water is not sprayed on to anyone nearby. Some areas require that the tube discharge outside the building. The tube should be as large as the tank fitting and the tube end should never be threaded, capped or plugged. The tube diameter should be at least as large as the TPR valve fitting. The tube should be able to withstand 250°F temperatures, should have no shut-off valve, and should be as short and as straight as possible.

An alternative to the high temperature function of the relief valve is a high temperature shut-off in the tank.

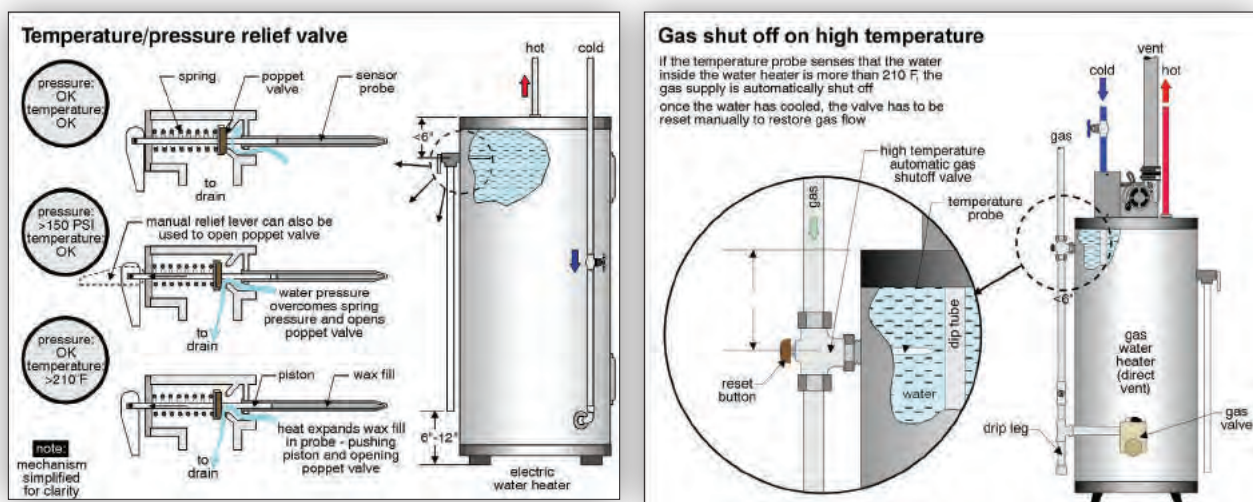

**AGE – NEAR END OF LIFE** The life expectancy of a water heater is typically eight to 12 years, although there are exceptions on both sides.

### 1.6.2 Tankless Water Heaters (Instantaneous or On-Demand Heaters)

- OPERATION** As the name suggests, tankless water heaters have no storage capacity. Tankless heaters are typically gas or propane fired and have a burner, heat exchanger, venting system, and controls. When the faucets and fixtures in the home are idle, the water heater is dormant. When there is a call for hot water, the heater detects the water flow and ignites the burners. These powerful burners quickly heat the water inside the small heat exchanger. As hot water leaves, fresh cold water is drawn in and heated as it passes through. An advantage of this system is that you can't empty all of the hot water out of the tank because there is no tank – just continuous hot water.
- NO STORED WATER** The other major advantage over conventional water heaters is energy savings. Tankless water heaters have no reservoir of hot water sitting idle. It takes energy to keep the tank of water hot all the time for when it's needed.
- SMALL SIZE** Tankless water heaters are much smaller than conventional heaters with storage tanks, and are usually wall-mounted. They do not take up much space.
- FUEL AND VENTING** Most tankless water heaters are fuelled by natural gas or propane and are vented through a side wall of the house or through roof venting, with specialized kits. In moderate climates the entire heater may be mounted on the exterior of the house. The vent system is built into the face of the appliance. When mounted outside in areas where freezing is a risk, some tankless water heaters fire briefly on a regular basis to prevent freezing. The pipes connected to the heater are also protected from freezing, typically by insulation and/or heat tapes.
- EFFICIENCY** Tankless water heaters are often more efficient than conventional water heaters, using modulating burners, direct venting and/or condensing combustion systems.
- MIXING VALVE** Most systems include a mixing (tempering) valve and a means of setting a maximum water temperature to avoid scalding. This tempering valve mixes some cold water with the hot water leaving the unit to reduce the temperature.
- REMOTE CONTROL** Some tankless systems include a remote control, which can be used to monitor the performance of the system, display error codes or change the desired water temperature.
- OTHER USES** Tankless water heaters may also be used to heat the home, either as part of a forced air combination system, or a radiant hot water system.

#### Common Problems with Tankless Water Heaters

- FUEL SUPPLY PROBLEMS** The water heater must have a continuous fuel supply. Malfunctioning burners, sensors or controls will cause poor operation or may result in the system not working at all, meaning no hot water. These units typically require much more gas than a tank type heater. Unless connected to a higher pressure (2 psi or greater) gas system, a direct switch from a storage tank heater to a tankless water heater is unlikely to work. Failure to provide an adequately sized gas supply can cause the system to periodically fail or not function at all.
- SCALE BUILD-UP** The small diameter of the heat exchangers means that these units are susceptible to clogging with scale, especially in areas with hard water. In hard water areas, annual de-scaling is recommended.

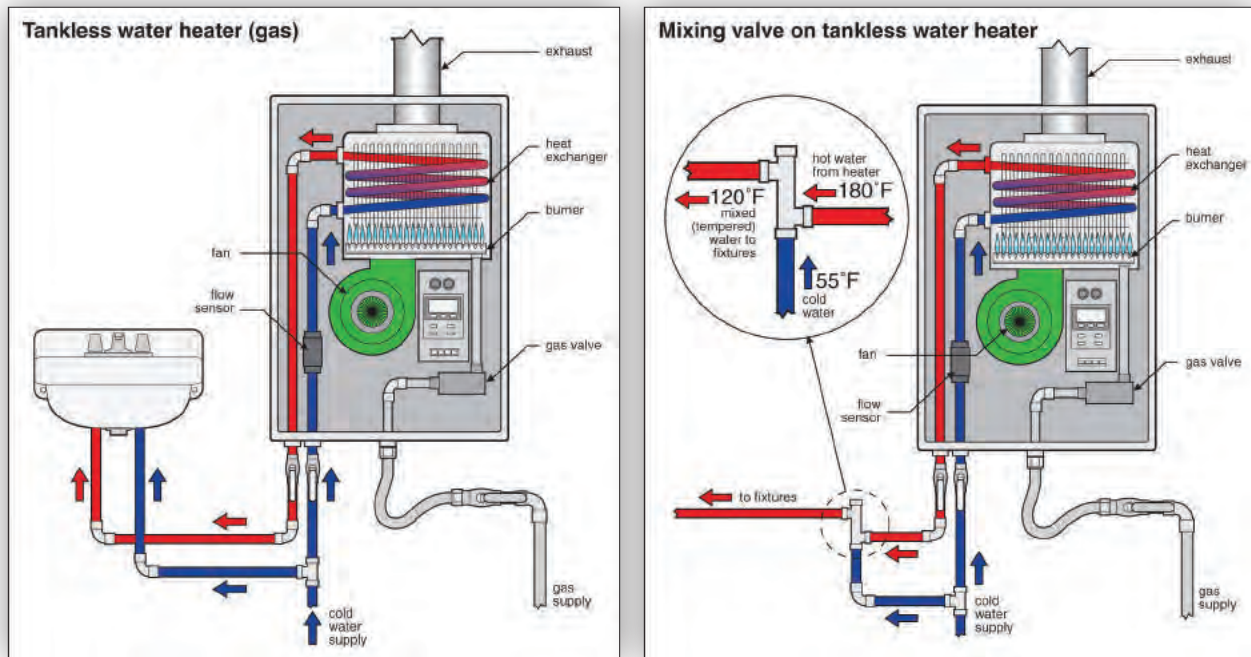

**LONGER WAIT** When a hot water faucet is turned on, it may take longer to get hot water with a tankless heater than a conventional system.

The delay between opening the faucet and getting hot water can be longer with tankless heaters than conventional tank heaters. Better tank locations and multiple tanks can help with issue. Some recent system designs allow for circulating loops to be used with tankless water heaters to get hot water to remote fixtures faster.

**MAXIMUM FLOW RATE LIMITED** The hot water flow rate is not only dependent on the heating capacity of the water heater and the output water temperature, but also on the inlet water temperature. Homes in northern climates draw water from colder sources, and since it takes longer to heat up colder water, tankless water heaters installed in these homes have lower hot water flow rates.

**MINIMUM FLOW RATE PROBLEM** The burners are triggered by sensors that detect the flow of water. If the flow rate is less than 1/2 gallon per minute, the burners may not turn on and no hot water will be delivered. Water-saving shower heads, for example, may not have enough flow to turn the water heater on, especially if the water heater needs a high flow rate before it will come on.

**RELIEF VALVE PROBLEMS** The temperature/pressure relief (TPR) valve lets water escape if the temperature or pressure is too high. This valve should be connected to a tube that discharges no more than six inches above floor level so hot water won't scald anyone nearby. Some codes require that the tube discharge outside the building. The tube should be as large as the tank fitting, arranged so water flows downward, and the tube end should never be threaded, capped or plugged. The tube should be able to withstand 250°F temperatures, should have no shut-off valve, and should be as short and as straight as possible. The tube should not be connected directly to another plumbing system, such as a plumbing vent or condensate drain, and the tube should supply relief venting for only one relief valve.



**HIGH COST** Tankless water heaters are considerably more expensive than conventional tank-type heaters, and although tankless units are more energy efficient, it may take a long time to recover the extra investment.

**HIGH MAINTENANCE** Conventional water heaters are relatively inexpensive due to their simplicity. Tankless water heaters are more expensive and more complex. Their complexity also means that maintenance and repairs can be more expensive. Isolating valves help simplify draining and other regular maintenance.

**DIRTY FILTER** If the heater is equipped with a water filter, this should be checked and cleaned monthly, or performance will suffer.

## 2.0 Waste Systems

**BLACK WATER, GRAY WATER AND STORM WATER** Plumbing waste is divided into two types. Black water is from toilets and contains human waste. Gray water is from bathing, clothes washing, dish washing or cooking, and does not contain human waste. Most municipalities require both types be treated as sewage. Storm water is from rain or melting snow. It is not typically treated as sewage.

Only a small percentage of the waste piping system is visible in a home.

### 2.1 Public Waste Systems

**DESCRIPTION** Most houses in built-up areas are connected to a municipal sewer system. This is a system in the street that allows waste from a house to flow by gravity into sewer piping. The waste is carried to a treatment facility where it is cleaned prior to being released.

**COMBINATION SEWERS** Older neighborhoods have a combination storm/sanitary sewer system. Storm water and sewage go through the treatment facility. Modern developments have a sanitary sewer to carry house waste and a separate storm sewer for rain and snow run-off. The storm water does not have to be treated, reducing the load on the treatment plant.

**RISK OF BACK-UP** Where homes have basements, flooding as a result of storm sewer back-up is less likely in a house with separate sewers. With combination sewers, a sewer back-up through basement floor drains will contain storm water and raw sewage. This is a health concern. In some areas, homeowners install one-way valves in their floor drain to

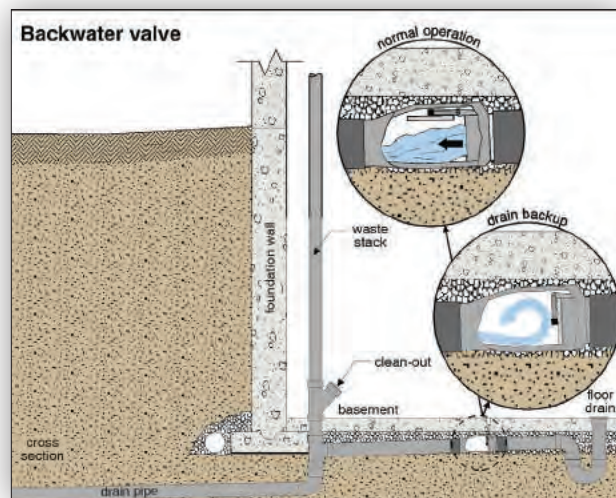

allow water down into the drain, but prevent water from coming back up. If pressures are high enough, sewage may back up through basement plumbing fixtures. In some cases, a check valve is put into the main drain line itself. These are short-term solutions and the municipality is often petitioned to improve the sewer system.

**FLOOR DRAINS AND DOWNSPOUTS** Where there are separate sewers, the floor drains should go into the sanitary sewer and gutters and downspouts should go into the storm sewer, or onto the ground several feet away from the building.

**SEWER LINE FROM HOUSE TO STREET** These lines are often clay in older homes and are vulnerable to collapse and obstruction by tree roots or soil.

**OVERLOADED DRAIN** There are a limited number of fixtures that can discharge into any given size of drain pipe. This can be a stumbling block during a house expansion or renovation. Although it is rare, it is possible that a house with a city sewer system is refused permission to add more plumbing fixtures.

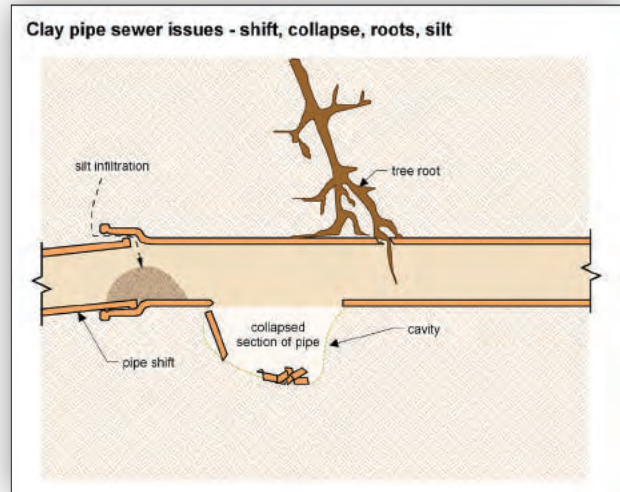

## 2.2 Private Waste Systems

**DESCRIPTION** The traditional private sewer system is typically a septic tank and weeping tile bed. This system is used where city sewers are not available. There are many variations of this. The septic tank is a watertight container usually made of concrete, steel or fiberglass. It serves as a holding tank, allowing heavy solids to settle to the bottom of the tank. Lighter materials that float, are also in the tank. The heavy solids are known as **sludge** and the lighter, floating materials are known as **scum**.

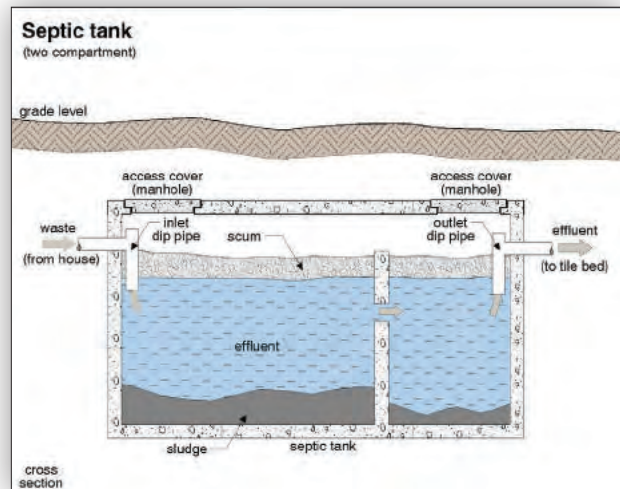

Most of the material entering the tank is in a liquid state. Within the tank, the majority of the solids are broken down to gases and/or liquids. The breakdown takes place as a result of bacterial action, both aerobic and anaerobic. The liquids are discharged from the tank into the tile bed. The gases escape through the plumbing vents in the home.

The tile bed is also known as a leaching bed, disposal field, soil absorption field or drain field. It consists of a network of perforated or open jointed pipes in trenches below the ground surface that allow the liquid waste (effluent) to percolate into the soil. The leaching bed is sized for the soil's ability to absorb effluent, and the amount of waste the system receives.

There are many variations on the conventional septic system, including closed holding tanks that are pumped out on a regular basis. There are also sophisticated systems with agitators and aerators that accelerate the chemical decomposition of the solids in the tank. These systems allow for smaller tile beds and are useful on smaller properties. While there is an advantage to this, the complexity of electrical and mechanical parts creates the potential for higher maintenance.

There are several types of tile beds as well. Special sand can be used, allowing for small tile beds. This is expensive, since the sand has to be brought onto the site, but it may be important to keep the tile bed small. These special tile beds may be used with conventional or specialized systems.

Septic systems should be kept away from supply wells and other sources of drinking water, for obvious reasons. Generally speaking, a well and a tile bed should be at least 100 feet apart. A well and septic tank should be at least 50 feet from each other.

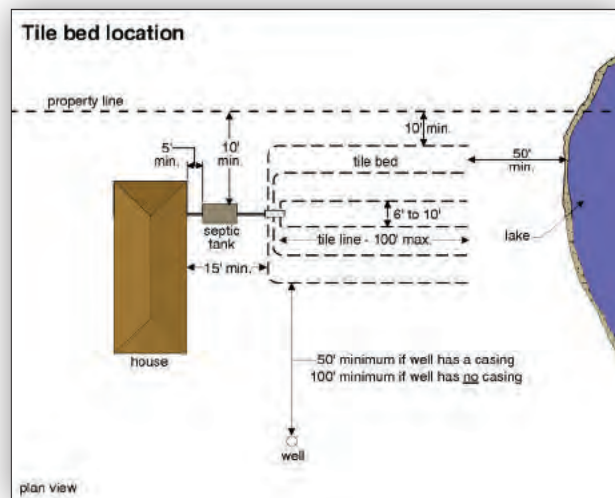
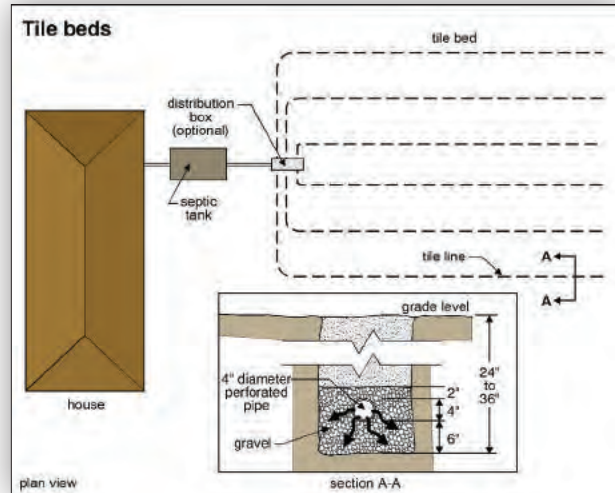

It is helpful to know the location of the tank and tile bed, the age of the system, and the installation and service history. Where building expansion is planned, the tank and tile bed can get in the way. The tile bed location can often be identified by greener, healthier grass growing above the bed. The homeowner or health authorities may have a record of the tank and tile bed location.

- MAINTENANCE** Septic systems require regular maintenance. The system should be inspected annually and the tank should be pumped out every two to four years, as required. Tile beds do have a fixed life expectancy (often roughly 25 to 30 years). This depends on many factors and is difficult to predict. Bleaches and strong detergents should be avoided where possible, since they may kill the bacteria in the tank. The amount of water entering the system should be minimized. Water saving toilets and showerheads reduce the load on a septic system.
- CITY SEWERS** There are several areas where houses with septic systems can now connect to street sewers. The connection to a municipal system can be expensive, but is typically less expensive than replacing a private waste disposal system.
- BUILDING ADDITION** Local authorities may refuse to allow an addition to a home, depending on septic system capabilities. A new septic system adds significantly to the cost of an addition.

### Common Problems with Private Waste Systems

- ODOR/ POOLING** A septic system that is not performing properly can pose a health hazard and should be treated as high priority. The condition of a septic system and tile bed cannot be determined during a home inspection. The homeowner should watch for water pooling above the tile bed, or an odor coming from the bed. Homes that have been vacant for several months may show problems when the system is back into service.

- SYSTEM FAILURE** Problems leading to failure of septic systems include overloading of the tile bed, soil breakdown around the tiles, high water tables, clogging of the tiles, and broken or cracked tanks and tiles.

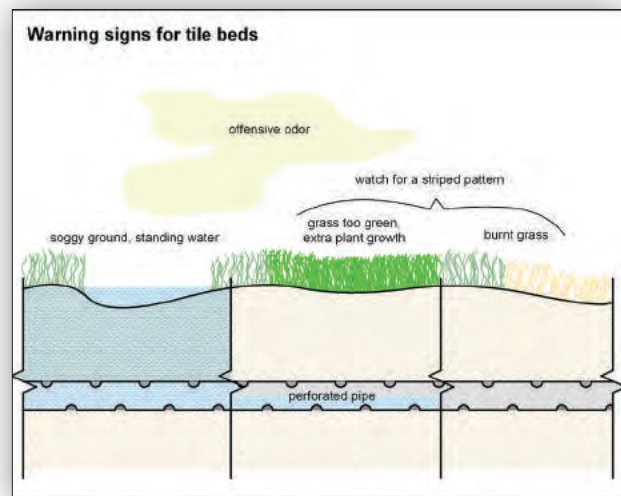

## 2.3 Waste Piping in House

**DESCRIPTION** Drain, waste and vent piping (referred to by plumbers as DWV) carry solid, liquid and gas waste products out of the building. Solids and liquids flow through the main drain, and gases escape through vent piping that extends through the roof. Several materials are commonly used in these systems.

**2.3.1 Galvanized Steel:** Galvanized steel venting was used in some areas. Vents carry air but do not carry water, so the pipe doesn't rust. Its life expectancy is very long, easily more than 50 years.

Galvanized steel drain and waste pipes were used in some cases. These have a relatively short life expectancy since the steel corrodes and the rough inner surface created by the corrosion can cause blockages as solids get hung up.

**2.3.2 Copper:** Copper waste plumbing was used commonly after World War II, up until the mid 1960s. Copper piping works well for branch drain lines, main stacks, and vent piping. It has become rare in homes, since plastic waste plumbing is less expensive. In multi-family construction, copper waste plumbing may be used where authorities will not allow combustible plastic piping due to fire spread concerns.

The joints in copper piping are soldered and an indefinite life expectancy is expected.

**2.3.3 Plastic:** Since the 1960s, plastic piping has become almost the exclusive waste plumbing material. Plastic piping may be ABS or PVC. It is used for drains, wastes and vents and connections are made with plastic cement (solvent). The piping is inexpensive, light, easy to work with and durable. Its only disadvantage is that it is somewhat noisy when water is running through it. Efforts to control the noise include wrapping it with fiber glass insulation.

**2.3.4 Cast Iron:** Cast iron piping was used for the main plumbing stack in houses up until the 1950s. Its life expectancy is 50 years and up. It employs a bell-and-spigot connection traditionally, with oakum packed into the joint and caulked with lead to seal it. There is also hubless cast iron pipe joined with neoprene sleeves clamped over the joint.

Cast iron is expensive and difficult to work with because it is very heavy. Cast iron waste piping generally fails in two ways. The pipe can rust through, often in a pinhole pattern. It is also prone to splitting along a seam, particularly on horizontal runs. When cast iron waste piping fails, it is typically replaced with plastic.

**2.3.5 Lead:** Lead waste plumbing was used until the 1950s to connect plumbing fixtures to a main cast iron or copper drain.

Lead was used because of its resistance to corrosion, and its workability. A piece of lead pipe can be bent fairly easily.

Lead piping is prone to leakage, usually at the connections. It is soft and susceptible to mechanical damage. It is typically replaced with plastic pipe. Lead waste lines are usually replaced during any major plumbing work, whether problems are being experienced or not.

**LEAD SUSPECTED** Since the sections of lead piping used are relatively small, they are often not visible. In houses built before the 1960s that have not been remodeled, we assume there is concealed lead waste plumbing that will eventually leak. We suggest replacing lead waste piping during any work that provides access to this piping.

### Common Problems with Waste Piping

**LEAKS – CRACKS/  
HOLES/JOINTS/  
DAMAGE** Waste plumbing leaks pose a health hazard and should be corrected immediately. Leakage may be from failed connections, damage, or pipe deterioration (holes or splits). Leaks may go undetected for some time, particularly if the fixtures are only used occasionally.

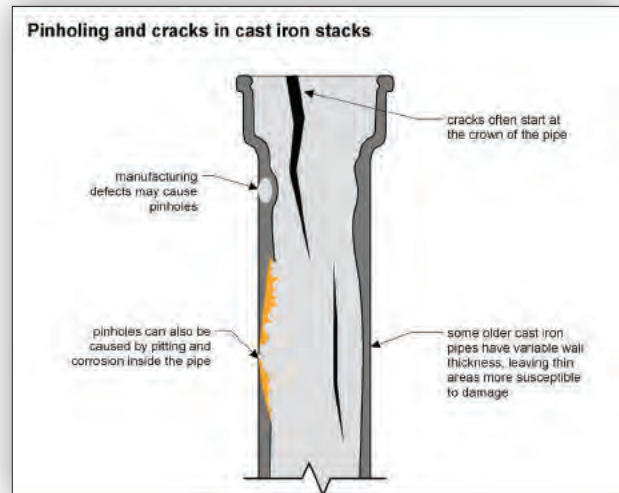

**IMPROPER SLOPE** Waste plumbing pipes may run almost horizontally, with a minimum slope of 1/4 inch per foot. Pipes that are at least three-inches in diameter are often permitted to have slopes as low as 1/8 inch per foot. Too little slope results in blockage and too much slope can cause siphoning at traps and poor drain performance. A maximum slope of roughly 1/2 inch per foot is often recommended. Where the slope would be greater, vertical sections of pipe are preferred. With house settlement or pipe sag, the minimum slope can be lost. Low spots in waste plumbing may lead to a blockage.

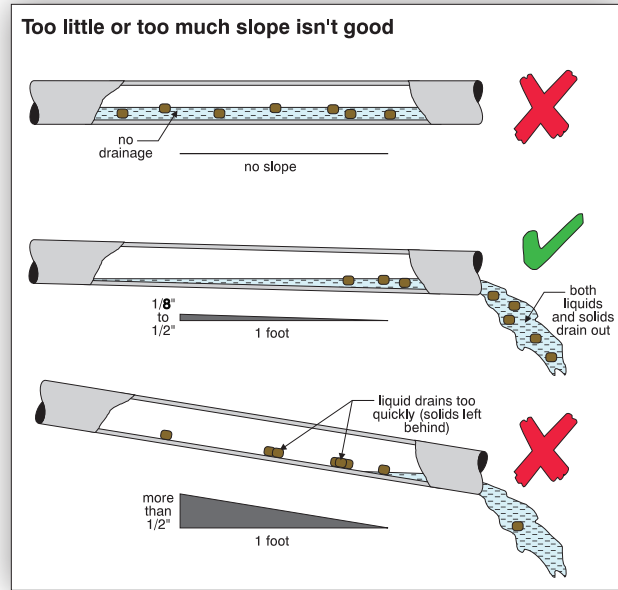

**POOR SUPPORT** Waste pipes should be well supported and protected from damage. Poor support may result in the slope problems described above.

**INAPPROPRIATE MATERIALS** Many materials used for waste plumbing were not intended for this use, and may be expected to have a short and troublesome life. These materials include rubber hoses, garden hoses, and non-approved plastic piping. Connections made with the wrong materials or wrong devices cannot be expected to perform properly. Special connectors are provided for special types of piping. Inappropriate materials raise questions about workmanship throughout the system. Traps and vents are commonly omitted on amateurish installations.

## 2.4 Traps

**DESCRIPTION** Traps are provided below house plumbing fixtures and are designed to hold some water in the waste piping system. The main purpose of a trap is to prevent sewer odors from coming back into the home through the fixture drain. There are several different styles of traps (P traps, S traps, and drum traps, for example). The P traps are considered the best for homes, as they are least vulnerable to siphoning or obstruction problems.

Traps are typically installed so they can be removed easily to clear obstructions or retrieve items that go down the drain.

Most fixtures require traps, although a toilet does not, since the water in the toilet bowl creates a natural trap.

**TRAP SEAL PRIMER** If water evaporates from floor drain traps that rarely see water, odors may get into the home. Since the 1960s, primers have been used for traps in many floor drains. This is typically a 1/4-inch clear plastic tube connected to a laundry tub faucet or toilet, for example. Water flows through the plastic tube into the floor drain whenever the fixture is used. Water is added to the trap to replace any water lost through evaporation. The same thing can be accomplished by pouring a bucket of water down the drain every month or so. Another solution is to fill the floor drain trap with mineral oil. It will not evaporate and is environmentally safe.

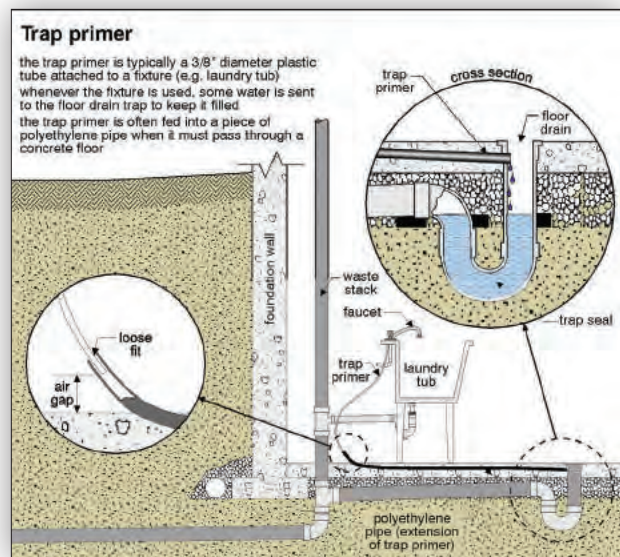
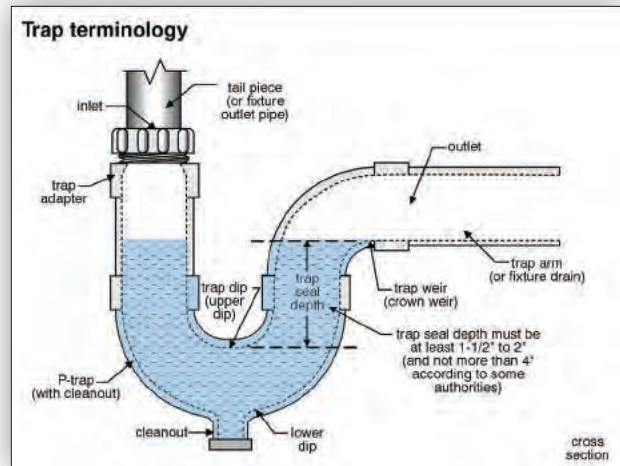



Common Problems with Traps

**MISSING/ LEAKING** Amateur installations may omit traps, and leaking traps are ineffective. Leaks in traps under sinks can be seen when water is flowing, but leaking traps under concealed fixtures such as bathtubs and shower stalls may not be discovered until damage is visible below.

Leaking basement floor drain traps are often not detected for some time. A sewer odor or air movement up through the floor drain may indicate a problem. (Air movement may be the result of downspouts discharging into the floor drain above the trap. This may not be a problem. It is also possible that the water has evaporated out of the trap, or the trap may be leaking.)

**S TRAP – SIPHON RISK** S traps often lead to siphoning problems and most plumbers recommend replacement with P traps. Bell traps, drum traps and crown vented traps are not recommended for plumbing fixtures in homes.

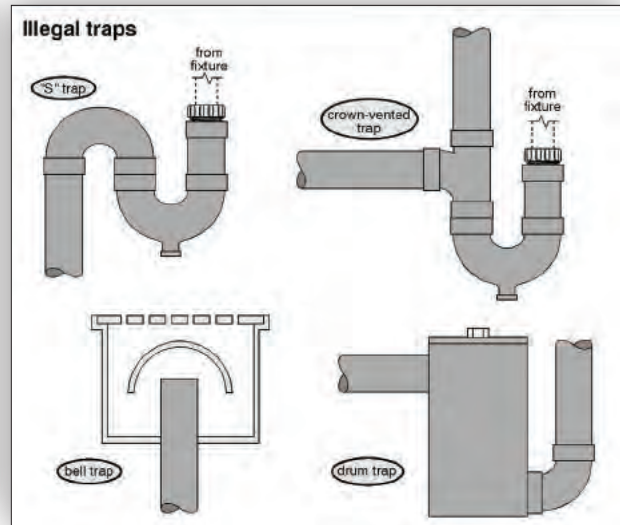
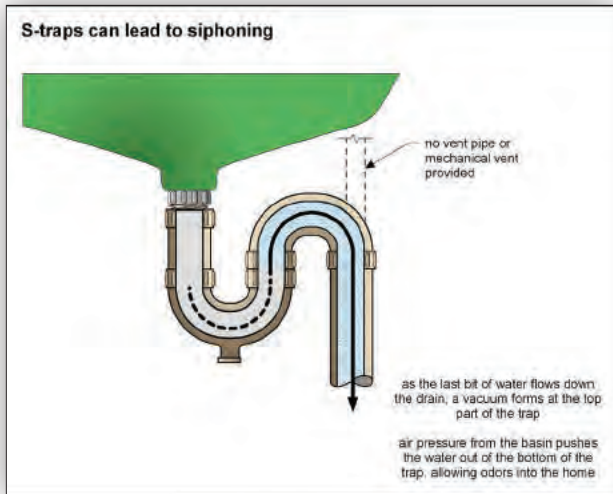
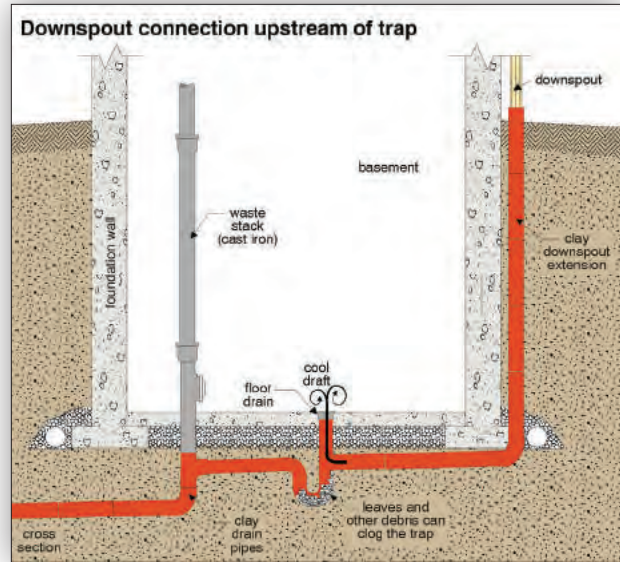

**OBSTRUCTIONS** Clogs develop at traps because the tight corners catch debris. Traps should be easy to remove in order to clear obstructions. Modern traps often include a drain plug at the trap bottom. This is useful for removing objects that are dropped down drains, but may not be large enough to allow clearing of an obstruction. Obstructions are sometimes cleared with plungers or plumber's snakes. In some cases, the piping has to be dismantled. This work can create a health hazard, and care should be taken when dealing with any waste water problems.

Older homes connected to city sewer systems often have traps in the front yard on the main waste system. These are common spots for obstructions, including tree roots. The waste line outside the house is also vulnerable to tree roots. Where the pipe has not been seriously damaged, a plumber's snake may clear a blockage. If the pipe is broken, digging and replacing are necessary. Video cameras are sometimes used to scan waste lines to find problems.

**FREEZING IN COLD CLIMATES** When a house is winterized, the supply pipes are drained. The waste pipes contain no water and are not susceptible to freezing. The traps, however, will freeze. The traps cannot simply be drained, since sewer odors will enter the house. Anti-freeze is provided for the traps. Since this anti-freeze will ultimately be flushed into the waste system (either city or septic), the anti-freeze should be a type that will not harm the environment.

**DOUBLE TRAPS – MAY CLOG** Two traps are not a good thing on any plumbing fixture. This arrangement may produce chronic blockages.

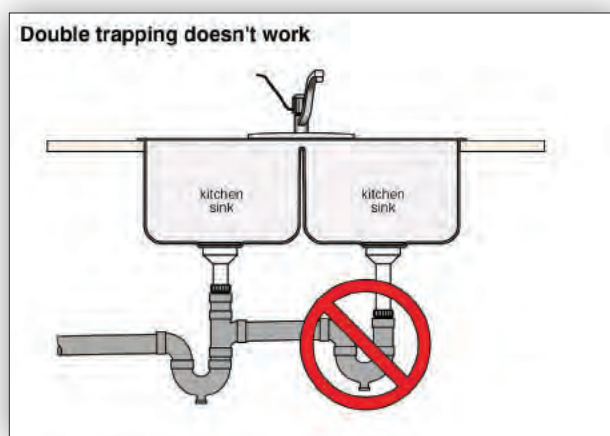

## 2.5 Floor Drains

**DESCRIPTION** Floor drains should be provided at the lowest living level of any house with a basement. Floor drains can be inadvertently covered if the basement floor is resurfaced. If the basement floor is lowered, the floor drain may be unwisely deleted.

Where an addition is provided, there may be no floor drain for this section of the basement. If this is lower than the original basement, this is a very risky situation.

The floor drain should be at the low point in the floor. This is always a compromise to some degree, since people do not like their basement floors to slope dramatically. Floor drains are often located close to the boiler, water heater or laundry area, where leakage is most likely. There should be a grate over the floor drain to prevent things falling in. The grate should be kept clear.

## Common Problems with Floor Drains

- MISSING** The most common problem is the absence of the floor drain. These are expensive to add, but do provide great protection in the event of a flood.
- POOR LOCATION** Floor drains are not always at the low point. The implication is that some water will remain on the floor if there is a flood. It is rarely cost effective to correct this.
- TRAP DRY** There should always be water in the floor drain trap. Sewer odors at floor drains are a result of leaking traps or trap water evaporating. Repairs are expensive but a good investment.
- GRATE** The grate should cover the top, but allow water into the drain.

## 2.6 Venting

**DESCRIPTION** Venting allows waste and water to flow properly. The venting performs three functions. It allows air in front of the water flowing through the waste pipe to be pushed out of the way. It allows air back into the waste piping after the water has gone by. Lastly, it allows sewer gases to escape outside through a vent stack.

**SIPHON** The second function is the most important. The trap at each fixture provides a water seal to prevent sewer odors from backing up into the house. After a fixture is used, some water should stay in the trap to provide the seal. If a system is not properly vented, water will siphon out of the trap. Let's look at how venting works.

As water runs through a drain pipe, we want to leave the last bit of water in the trap to seal off the waste piping system from the house air. It is difficult to separate that water into two pieces (leaving the last part in the trap) because the space in the middle forms a vacuum. The water in the trap can be siphoned out and down the drain.

A vent just downstream of the trap allows air into the pipe, preventing a vacuum and allowing the last bit of water to remain in the trap. With the exception of some floor drains, all fixtures should be vented.

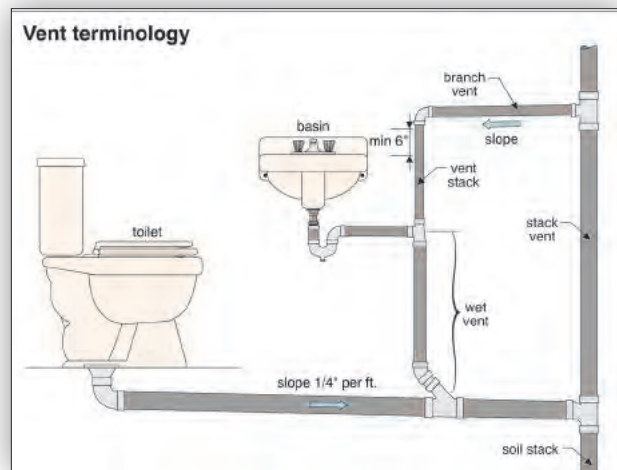

As a rough rule, any fixture within five feet of the main stack does not need a separate vent, because the main stack acts as a vent. Where fixtures are more than five feet from the main stack a vent should be provided that extends out through the roof. Vents may connect to a main stack above all the fixtures in the house.

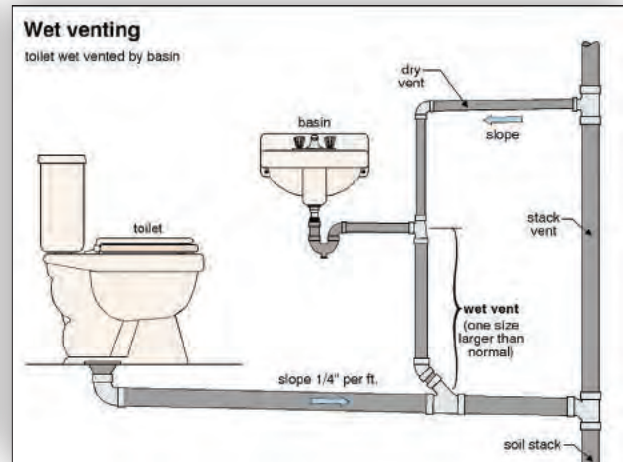
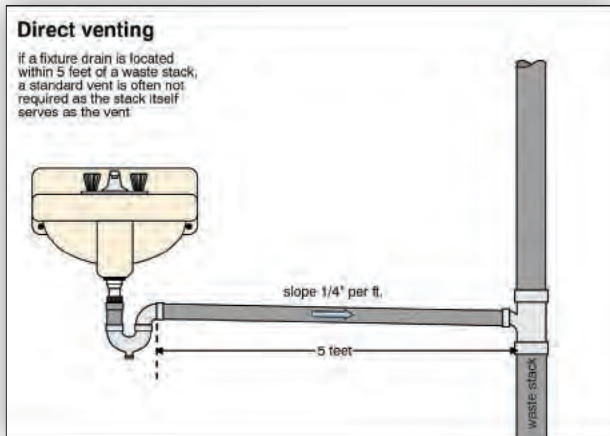

**MATERIALS** Vent piping may be cast iron, copper, galvanized steel or plastic. Because vent piping only carries air (no water) it tends to last a long time no matter what material is used.

### Common Problems with Venting

The implication of venting problems is unhealthy sewer gases getting into the home.

**MISSING/ INCOMPLETE/ INEFFECTIVE** The venting system is almost always concealed from view, except in a few small areas. A siphoning or gurgling noise when water is drained out of a plumbing fixture suggests venting problems. This indicates the trap is siphoning and losing its water. A sewer odor at a fixture indicates a trap or venting problem.

**AIR ADMITTANCE VALVES** Unvented fixtures may siphon. Traps with no water allow unhealthy sewer odors into the home. Air admittance valves are mechanical devices that simulate vents. They allow air to be drawn into the waste plumbing system under negative pressure to prevent siphoning, but prevent any air escaping from the plumbing system under positive pressure. Air admittance valves should be installed in an accessible, ventilated area. These devices are a low cost alternative to venting, although they are not as good as conventional venting. Some plumbing authorities will not allow these.

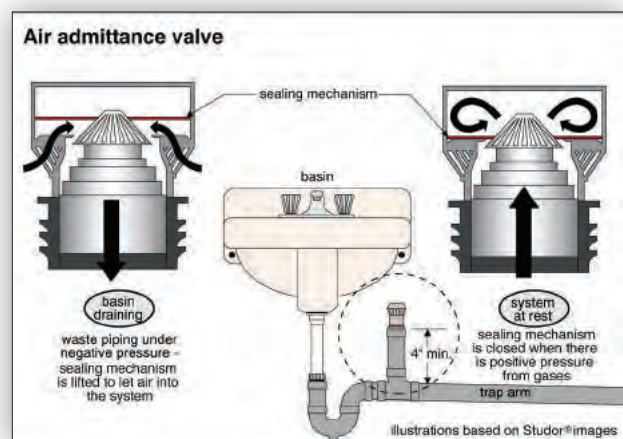

**AUTOMATIC AIR VENTS** While air admittance valves are approved in some areas, older style automatic air vents (see illustration), which rely on metal or rubber components, are not approved and should be replaced.

**HEIGHT/ LOCATION PROBLEMS** The vent pipe should extend at least six inches up through the roof of the house. When the vent extends through a roof that is used as a deck, the vent should be at least seven feet above the deck (taller than most people). Vents should not terminate in the attic, since this may allow odors into the house. In cold climates, this adds very moist warm air into a cold attic, leading to condensation and frost damage.

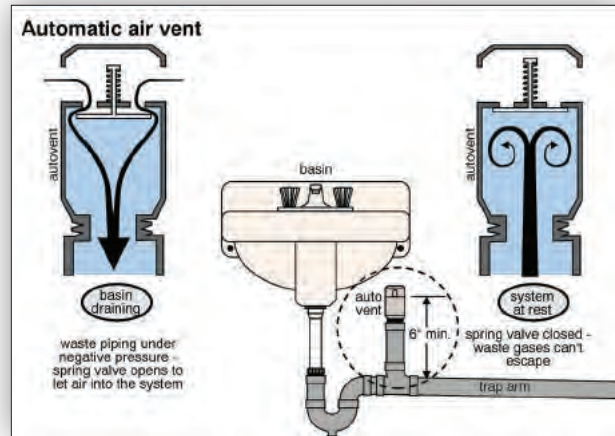

Vents should terminate at least three feet above any door or window openings within 10 feet horizontally. Vents should be at least 12 inches from a wall.

**FROST CLOSURE IN COLD CLIMATES** In cold climates, some recommend that the vent extend only about 12 inches above the roof line. Very long vents may be subject to frost closure in the winter. The warm moist air inside the vent cools as it contacts the cold outdoor section of the pipe. The moisture condenses and freezes on the inner pipe walls. In a prolonged spell of cold weather, this frost can build up and block the vent. This may lead to sewer odors inside the home. Vents should be at least three inches in diameter where they penetrate the roof system to reduce the risk of frost closure. Increasing the pipe size just before the vent passes up through the roof also helps prevent closure.

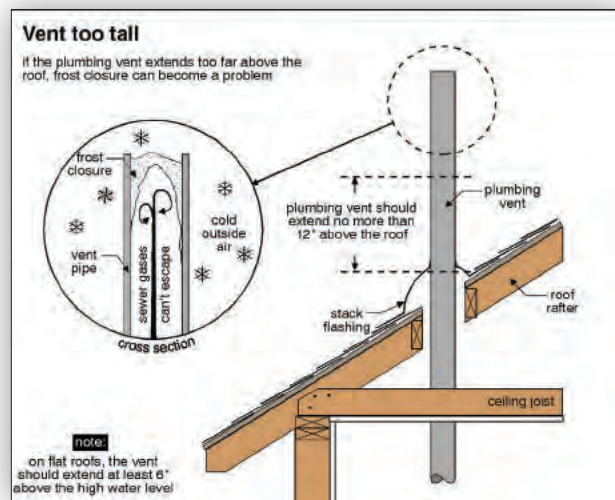
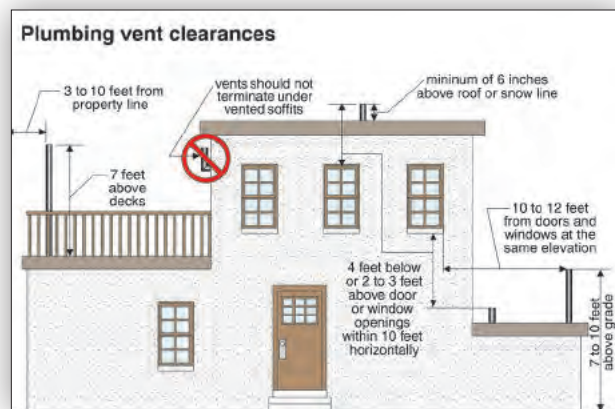

**CONNECTION/ PIPE SUPPORT** Since the venting system only carries air, leakage is usually not a big problem. Deterioration of the piping is also very unusual, although poor connection or poor pipe support is a possibility.

**WET VENTS** Wet vents (vents that also serve as drains) can become clogged or deteriorate as a result of the waste flowing through them.

**OUTSIDE VENTS** When a basement bathroom is added to a home, it is difficult to run a vent pipe up through the house and roof. A vent is often run out through the wall and up the outside of the building. This is acceptable although not attractive, and frost closure problems in cold climates both are more likely with this arrangement.

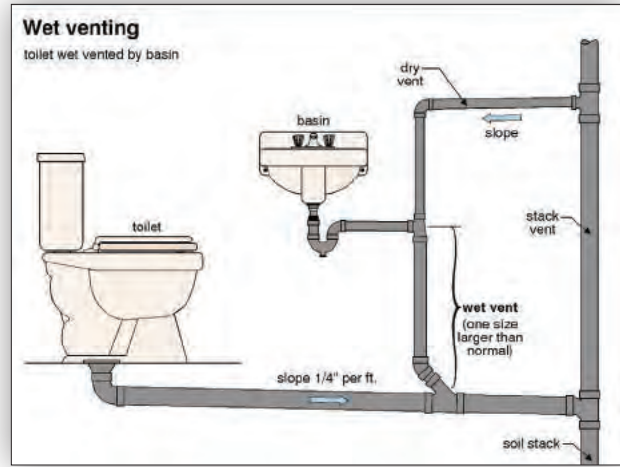

### 2.7 Sewage Ejector (Solid Waste) Pumps

**DESCRIPTION** Solid waste pumps are used where gravity cannot carry toilet waste away. Basement fixtures in a house with a septic system usually need a solid waste pump to carry the waste up to the main sewer line, which typically leaves the house halfway up the basement wall. These systems are expensive and relatively complex.

Solid waste pumps are installed in a tank with a sealed top. The plumbing fixtures drain into the tank, and as the tank fills, the pump comes on, discharging the waste to a city sewer or a septic system. The specially designed pump handles both solids and liquids. The incoming line is typically three-inch diameter and the discharge line is usually two inches. A vent pipe is typically connected to the top of the tank. Some have high level alarms to notify the homeowner of a malfunction.

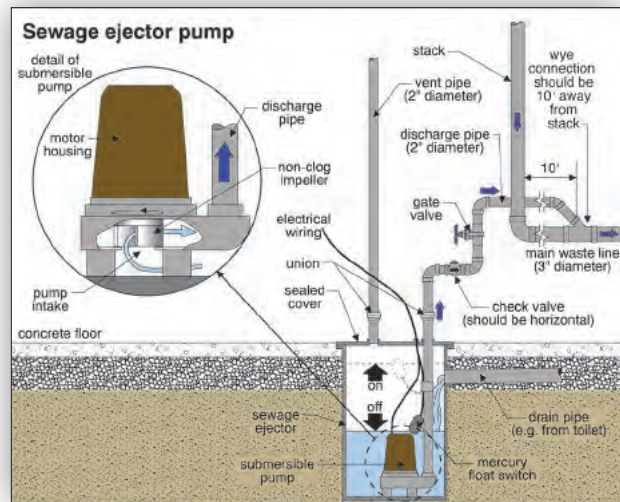

The discharge line should be equipped with a union (a connection fitting), a check valve (to prevent sewage moving backwards), and a shut-off valve, in that order.

## Common Problems with Sewage Ejector Pumps

**ELECTRIC SUPPLY/ MOTOR/PUMP PROBLEMS** Problems can develop with the electrical supply or the electric motor. The pump can become obstructed or damaged.

**LEAKS/CLOGS** Leaks can develop in the holding tank, piping, or the connections. Clogs can develop in the piping systems draining into or out of the tank. Care must be taken with these systems, since raw sewage is a health hazard.

### 2.8 Sump Pumps

**DESCRIPTION** A sump pump is used to lift storm water from a low spot into a storm sewer or other discharge point, well away from the house. This electric pump is located in a sump (pit) below the basement floor level. Sumps are typically plastic or concrete tubs. Foundation drainage tiles and/or downspouts may discharge into the sump. A float switch activates the pump as the water level in the sump rises.

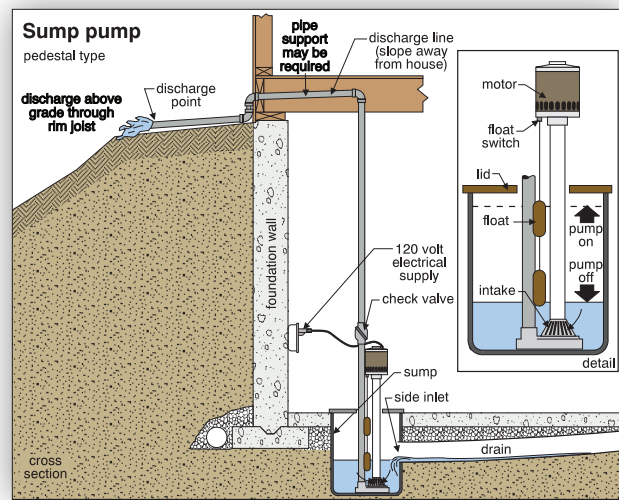

Pedestal type sump pumps are more common, less expensive and less reliable than submersible pumps.

## Common Problems with Sump Pumps

**SUMP DETERIORATION** Problems occur if the sump deteriorates and allows debris or earth to enter the pump mechanism.

**PUMP FAILURES** A sump pump failure can lead to considerable damage due to flooding. There are several reasons for failures. A back-up pump in the sump, a high-water alarm and back-up power are all options.

**ELECTRICAL PROBLEMS** If the electric supply to the pump is interrupted, during a power failure for example, the sump may flood. Since power failures often occur with heavy rains and storms, this can be a problem.

**PUMP AND MOTOR ISSUES** The pump mechanism or electric motor may become defective. Since the pumps are relatively inexpensive and easy to install, many people keep a spare pump on hand in case of failure. This, of course, will be a function of how critical the sump operation is. In many cases the sump operates only a few days per year; in other situations the pump may operate almost continuously.

**FAILED FLOATS** Problems with the float system that controls the pump are very common. These are inexpensive to replace and adjust, but regular maintenance and inspection should include testing to verify that they are not damaged, disconnected or entangled with the pump, the sump wall, or any foreign objects.

**DISCHARGE PIPE PROBLEMS** The discharge piping for the pump is often a source of leakage. The plastic piping can easily be crimped or damaged. It is often difficult to find the discharge point of the piping. It may discharge into a city sewer system, a storm ditch at the front of the property, a French drain (a buried gravel pit designed to allow water to accumulate quickly and dissipate slowly by soaking into the soil), or simply onto the ground, several feet from the house. Water in the discharge pipe may freeze in cold climates if the pipe slope is poor.

## 2.9 Laundry Tub Pumps

**DESCRIPTION** Where a laundry tub cannot drain by gravity into a waste system, an electric pump is usually provided below the tubs to carry water into a municipal sewer, a septic system or a dry well. Most municipalities now require gray water (waste water which does not contain human waste) to discharge into a sewer disposal system.

Some pumps have an automatic control (typically a float system within the tub), although many are manually operated by wall switches.

**COMMON PROBLEMS WITH LAUNDRY TUB PUMPS** The issues with laundry tub pumps are similar to sump pump problems. See above.

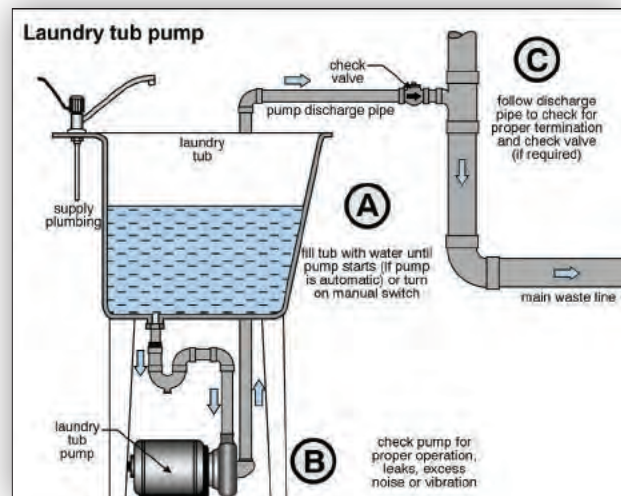

## 3.0 Plumbing Fixtures

### 3.1 Sinks

**DESCRIPTION** A sink is a fixture used for cleaning things, rather than people. A basin, on the other hand, is used for personal washing. We refer to a kitchen **sink**, but to a bathroom **basin**. Basins are also called **lavatories**.

Sinks may be made of stainless steel, enameled steel, enameled cast iron, copper, porcelain, and plastic, for example. Each material has its advantages and disadvantages. We don't want sinks to absorb things and support bacteria growth. Some areas do not permit sinks made of wood, concrete or tile.



A sink with an integral platform at the back for the faucets is generally better than a sink without such a platform. Since faucets often leak, we want the water to run off the platform into the sink, rather than onto the counter top. This is only an issue if the counter can be damaged by water. Particleboard counters are more vulnerable than granite counters, for example.

Sinks should have a crossbar, strainer or stopper to prevent large objects getting into the waste piping. Sinks typically do not have an overflow because we don't want bits of food collecting in an overflow pipe.

**Common Problems with Sinks**

**LEAKAGE/ OVERFLOW** Leakage may be the result of a cracked or rusted sink, or a poor drain connection. Sinks should not have overflows, though multiple sinks may have dividers that allow overflowing water from one sink to go into the next sink rather than onto the counter.

Poorly-secured sinks are prone to leakage. Sinks may rust or crack over time.

**CROSS CONNECTION** Cross connections with sinks are possible. A vegetable sprayer or extendable faucet can end up in a sink full of dirty water. Please refer to the discussion of Cross Connections on pages 304 and 305.

**AIR GAP FITTINGS FOR DISHWASHERS** In some areas, air gap fittings are required on the discharge from a dishwasher. This is typically a chrome fitting that projects roughly three inches above the counter top adjacent to the kitchen sink. Waste water from the dishwasher travels up to the air gap fitting and back down through another line into a food waste disposal or drainage piping. The flood level of the fitting must be above the rim of the kitchen sink and the kitchen counter top. This fitting prevents water or other waste from flowing back into a dishwasher. If water discharges from the air gap fitting during dishwasher use, service is required.

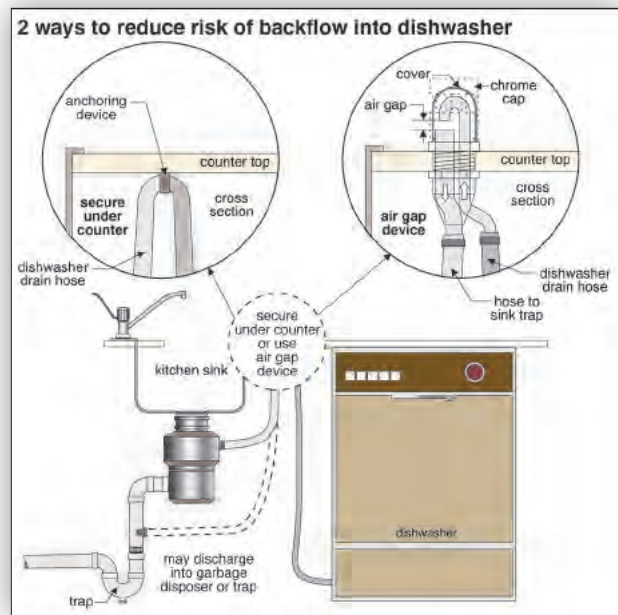

Air gap fittings are not required if the dishwasher has an integral backflow preventer.

**SECURE A HIGH LOOP UNDER COUNTER** When an air gap device is not required, the dishwasher's drain hose should be secured to the underside of the countertop creating a high loop to help prevent backflow.

### 3.2 Basins

**DESCRIPTION** Basins, typically located in washrooms or bathrooms, may be made of several materials including stainless steel, enameled steel, enameled cast iron, copper, vitreous china, plastic, marble simulated marble, etc. None of these materials will last forever, and all have their strengths and weaknesses.

Basins should have a crossbar, strainer or stopper to prevent large objects getting into the waste piping. Basins typically have overflows.

#### Common Problems with Basins

**LEAKAGE/ OVERFLOW** Common problems include leakage and overflowing. Most bathroom basins, but not all, contain overflows. Where there is no overflow, the basin should not be left unattended while filling.

**RUST** Many enameled steel basins have a welded steel overflow, which is a common spot for rusting to occur. This rusting, visible from the underside, will eventually result in leakage and can appear just a few years into the life of the fixture. Some basins rely on a siliconed joint rather than a welded seam.

**CRACKS** Cracking of cultured marble sinks around the drain connection is common. This does not normally lead to leakage in the short term, but is unsightly. Ultimately the basin has to be replaced.

Cross connections with basins are possible, although not common. Please refer to the discussion of cross connections on pages 304 and 305.

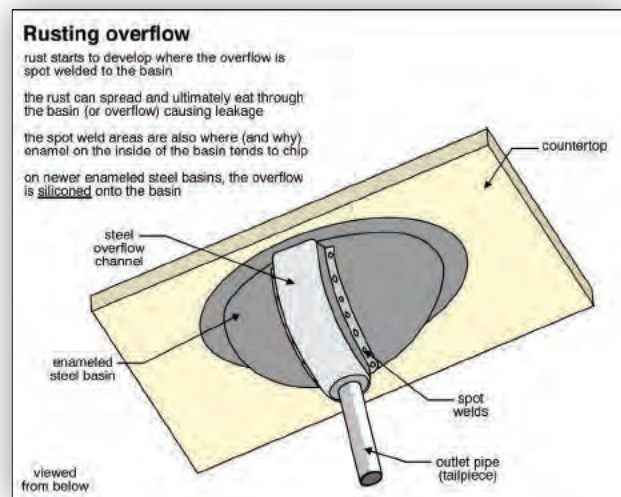

### 3.3 Laundry Tubs

Traditional concrete laundry tubs have been replaced, for the most part, by steel and plastic tubs.

#### Common Problems with Laundry Tubs

**CRACKS/LEAK** The concrete tubs, although durable, are heavy and ultimately are prone to cracking. Replacing the tubs is not expensive. Lead waste plumbing common with older tubs is usually replaced with plastic pipe when the tubs are replaced.

**CROSS CONNECTIONS** Older laundry tubs may be subject to cross connections. It should be ensured that the faucet set is above the laundry tub, so there is no possibility of the faucet becoming submerged when the tub is full. Refer to the discussion of cross connections on pages 304 and 305.

### 3.4 Faucets

**DESCRIPTION** There are many types and styles of faucets with a wide range of qualities available. The traditional compression faucet employs a stem washer to shut off the water when the washer is turned down against a seat. Leakage through the faucet usually means a deteriorated washer. Leakage around the handle of a faucet usually indicates deteriorated packing. Both problems require minor repairs, and leaking packing is considered to be a greater threat than a leaking stem washer. A leaking washer will only allow water to drip into the fixture, while leaking packing will allow water to run onto a counter top, where it may cause damage.

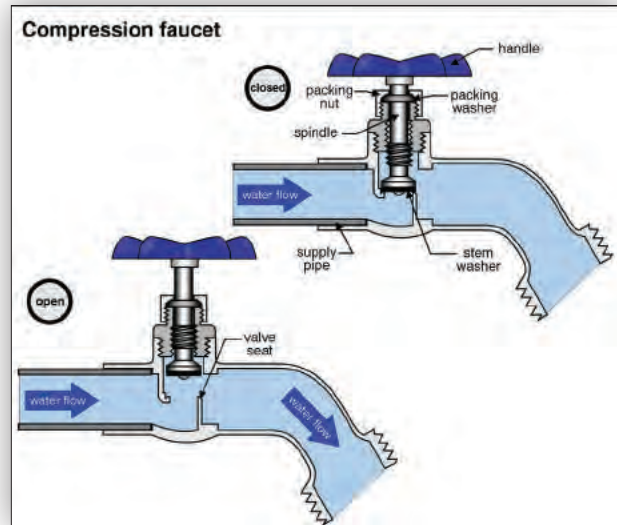

A leaking washer will only allow water to drip into the fixture, while leaking packing will allow water to run onto a counter top, where it may cause damage.

Many modern faucets use a cartridge, ceramic disc, or ball valve to control water flow. Single-lever and twin handle faucets are both common for sink, basin and bathtub use.

There are sophisticated faucets available for showers, which will maintain the temperature selected, irrespective of pressure changes in the system. For example, if someone is having a shower, and two other cold water fixtures in the house are turned on, the cold water pressure to the shower will decrease. This can lead to scalding, since there is now much more hot water being delivered than cold.

A temperature- or pressure-sensitive mixing valve will adjust to this automatically, maintaining the desired temperature.

## Common Problems with Faucets

**LEAKS/DAMAGE** Leakage and difficulty in operating the valve are the two most common problems. Damaged faucet handles may be dangerous if there are jagged edges.

**LOOSE** It is common for a faucet to be poorly secured to the wall, counter top or fixture. This is a minor problem, although it can be difficult to access. If not corrected, it may result in leakage.

### 3.5 Outdoor Faucets (Hose Bibs)

**DESCRIPTION** Outdoor faucets are conventional cold water supply valves, typically. The water is shut off by another valve in the building interior during the winter months in cold climates. The outside valve is typically left open to allow any water in the pipe to escape. The inside winter shut off valve may be provided with an auxiliary bleed valve to allow any water between the two valves to escape.

Backflow preventers are now required in many jurisdictions on outdoor faucets to protect against cross connections. See cross connections on pages 304 and 305 .

**FROST-PROOF** Frost-proof valves for hose bibs do not have to be shut off in the winter in cold climates. These valves have a long stem that penetrates through the building wall and shuts off the water supply inside the building. These valves should be sloped to drain any water in the stem to the outdoors.

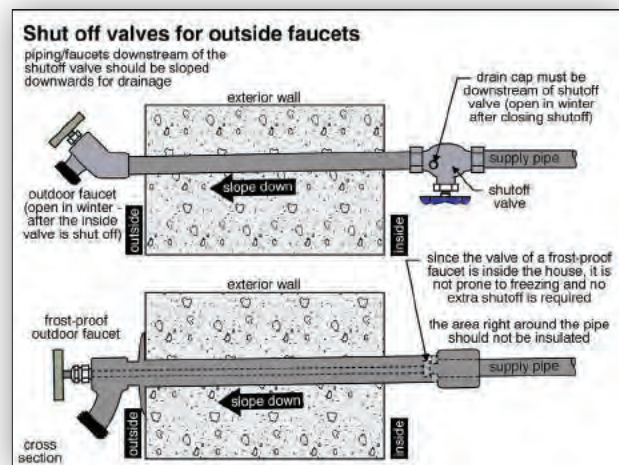

## Common Problems with Outdoor Faucets

**LEAKAGE/DAMAGE** Outdoor faucets are susceptible to washer and packing failure and resultant leakage. They are also more vulnerable to mechanical damage than inside valves. Because of their exposure to extremes of weather, it is possible for the valves to become inoperative. Replacement of these is not a major expense.

**BACKFLOW PREVENTERS** Missing backflow preventers can be added easily and inexpensively.

**FREEZING** Conventional hose bibs can be damaged by freezing, if they are not turned off in cold weather.

### 3.6 Toilets

**DESCRIPTION** Most toilets are made of vitreous china, although other materials are occasionally used. There are several different styles of toilets and several different flush mechanisms. Some of the older toilets have relatively weak flush mechanisms and are more prone to clogging. Many modern toilets are low-flush, designed to conserve water. Some of these do not handle solid waste as well as traditional toilets. Dual-flush toilets use different amounts of water for liquid and solid waste. Toilets are the only common plumbing fixture that does not need a trap – because there is one built in.

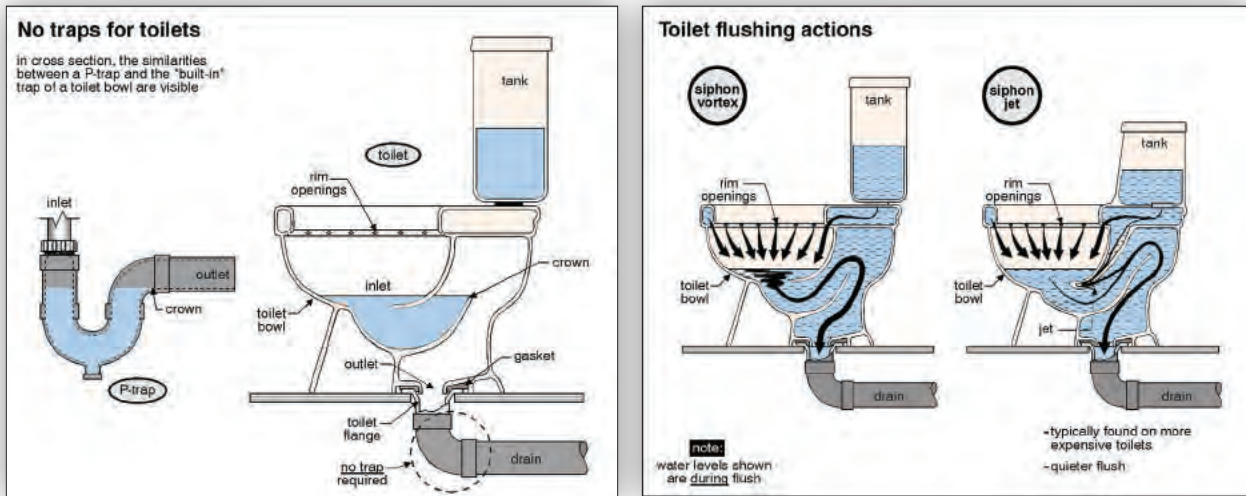

### Common Problems with Toilets

**LEAKAGE** Problems can occur with leakage at the toilet supply line, at the storage tank, at the connection between the tank and the bowl, at the bowl itself (e.g. if the bowl is cracked), or at the connection between the toilet bottom and the drain pipe. Damage to the floor finishes and floor structural components around toilets is a common problem.

**LOOSE** Toilets are often poorly secured to the floor system. This can result in leakage at the base of the toilet over the long term. It is usually easy to secure a loose toilet, unless the floor has rotted.



**INOPERATIVE / RUNNING CONTINUOUSLY** If a toilet does not flush at all, there is usually no water in the tank due to a supply problem. If the toilet runs continuously, this means there is leakage from the tank into the bowl. While this will not cause any direct water damage, a continuously running cold water pipe and a continuously running drain may

lead to condensation problems on the outside of these pipes, particularly during warm humid weather. The resulting water damage can be significant. A continuously running toilet also wastes a good deal of water. Repairs to the flush mechanism are needed. The flush mechanism is a relatively complicated mechanical device and problems may develop with the float, rod, plunger, ball cock, filler tube, refill tube, trip lever, tank ball, etc. These are typically inexpensive repairs.

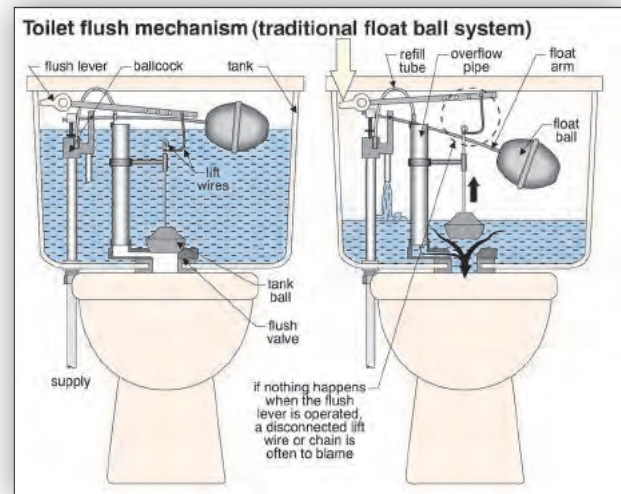

**SLOW FLUSH** Slow flushing toilets are usually partially obstructed. In some cases, a plunger will clear the obstruction; in others, a plumber's snake is necessary. Occasionally, the toilet has to be temporarily removed to get at the problem.

**SEAT ISSUES** Problems with the toilet seat are not functional from a plumbing standpoint. Seats can usually be replaced readily.

### 3.7 Bathtubs

**DESCRIPTION** Bathtubs may be free-standing or built-in, and may be enameled cast iron, enameled steel, fiber glass, plastic, etc. Custom bathtubs can be made of tile, marble or copper, for example.

**SLOPE** The bathtub should be installed so water in the tub will flow naturally to the drain, and so water on the shelf around the perimeter of the tub will run into, not out of the tub.

Cast iron bathtubs are credited with keeping the water hotter than the modern tubs, although this is not a big issue for most people. Some builders add insulation around modern steel and acrylic tubs, to keep the water hot and reduce the noise of water hitting the tub. Sprayed-on insulation also makes the tub feel more rigid and substantial.

Common Problems with Bathtubs

**DAMAGE/ LEAKAGE** Bathtubs are susceptible to chipped enamel, rusting, and leakage through supply or drain connections.

**LEAK AT OVERFLOW** Bathtub overflows are a common source of leaks. Since they are not used on a regular basis, they are often installed poorly with the potential for leakage. When the bathtub does overflow in an emergency, water may escape around the overflow connection. A home inspection does not include testing overflows, since they often leak, causing concealed damage.

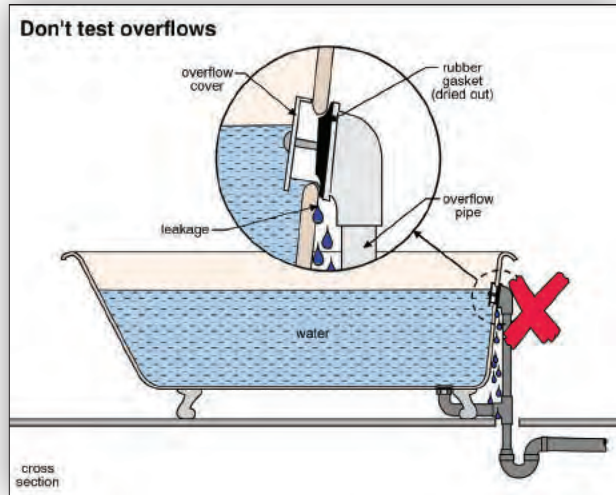

**LEAK AT TUB/TILE INTERSECTION** When leakage is noted on a ceiling below a bathroom, the source is usually the bathtub area. In many cases, the leakage is not from the bathtub, but from the connection between the tub and tile enclosure. Conventional bathtubs have a one-inch lip around the top of the tub on the side and ends against the wall. When the wall is finished, the lip cannot be seen, since it goes up behind the ceramic tile. This lip is intended to minimize leakage at the tub/tile intersection. This lip is often not effective in preventing leaks. Early signs of a problem may be loose ceramic tiles.

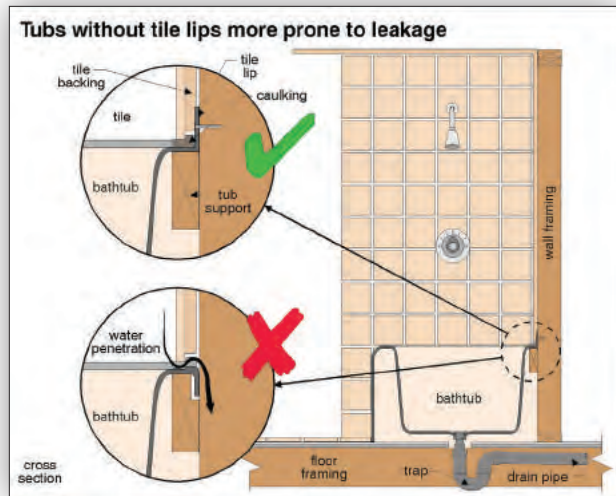

### 3.8 Bathtub Enclosures

**DESCRIPTION** Bathtub enclosures may be ceramic tile, plastic, marble or other stone, simulated marble tile, glass tile, plastic tile or plastic laminates. All of these materials, if properly installed, are considered acceptable. Modern one-piece acrylic or fiber glass enclosures are also considered effective if properly installed. Porous materials including wood enclosures and hardboard materials with a simulated tile finish are not considered good long-term materials where a shower is to be used.

**TILES IN CONCRETE** In older houses, it is common to find ceramic tiles set in concrete. This is a good installation method and the life of the tile system can be 50 years or more. This system, however, is expensive to remove during remodeling.

**TILES GLUED ON** Modern tile application typically uses an adhesive, that bonds the tile to plaster, drywall, plywood or a lightweight concrete board. This method of securing tiles is less desirable since the adhesive can be weakened as water gets in behind the tile. Perhaps more importantly, concealed wall surfaces such as plaster, drywall or wood can be damaged by the water.

**BEHIND THE TILES** Where drywall is used in a bathtub or shower stall enclosure behind the tile, water-resistant type (green drywall) is better than ordinary drywall. This is not waterproof drywall, but does afford some protection against moisture. Cement board (a lightweight concrete panel) is better still.

**GROUT AND CAULK** Water penetrates a tile enclosure two ways, typically. Openings in grout joints or poor grout mixes will allow water to pass through during showers. Secondly, the connection between the tile and the tub is a weak spot. No matter what quality caulking is used, over a period of time, an opening will develop between the tub and tile. Although there is often a lip on the tub going up about one inch behind the tile, this does not always prevent water damage.

Since bathtubs will flex to some degree, when filled with water and a person, this movement contributes to deterioration of the caulking.

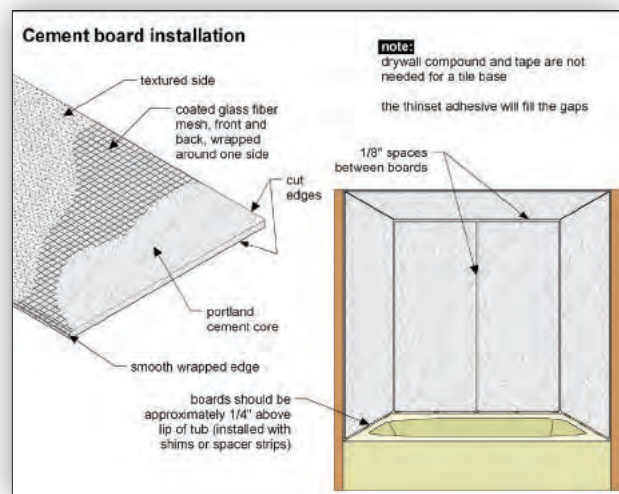



### Common Problems with Bathtub Enclosures

**LEAKS AROUND TILE OPENINGS** Leakage can occur in the bathtub enclosure through openings created for faucets, spouts and soap dishes, for example.

**LOOSE TILE** When the tile is loose or buckling, the tile must be removed, and in many cases the support material (plaster, drywall or plywood) must also be replaced. Low-density concrete boards are better than drywall or plywood in terms of rigidity and resistance to moisture.

**RISK OF CONCEALED DAMAGE** There is often considerable concealed damage around and below bathtubs and showers that cannot be identified until things are pulled apart.

**DAMAGE AROUND WINDOWS** Windows can be damaged by water in bathtubs with a shower. Interior window sills should be avoided as much as possible, as should any other horizontal ledges that allow water to collect.

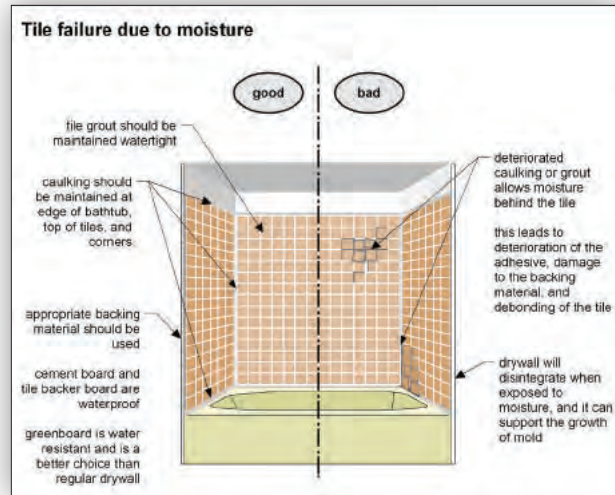

### 3.9 Shower Stalls

**DESCRIPTION** Traditionally, shower stalls were often lined with ceramic tile, glass or marble tile. Modern one-, two- or three-piece shower stalls in fiberglass or acrylic are popular. Some of these are quite good quality. One of the problems with fiberglass and acrylic is that abrasive cleansers will scratch the surface, making it almost impossible to clean.

Metal shower stalls are typically low quality and are prone to rusting around the bottom within the first few years.

### Common Problems with Shower Stalls

**TILE LEAKAGE** Shower stalls are notorious for leakage through the tile work. Since there is lots of tile work in traditional shower stalls (all walls and the floor typically), any small openings in the grout or caulking may cause problems. Because shower stalls are often poorly lit, small tile flaws often go unnoticed until damage appears below. Leakage through the faucet and soap dish joints is common.

**BOTTOM PAN LEAK** The construction of the tile shower stall includes a lead (traditional) or neoprene (modern) pan around the bottom of the stall. This one-piece pan below the tile typically extends up about six inches above the bottom of the shower floor on all four sides. This pan will catch minor leakage, although if it is not well secured around the drain, leakage will develop here. In the event of a serious leak, this pan will not be effective. Tile shower stalls are very expensive to rebuild, and are sometimes replaced with fiberglass or acrylic shower stalls. One-piece china shower bases are also available. New shower enclosure approaches include a continuous membrane in the pan and up the sides of the stall behind the tile.

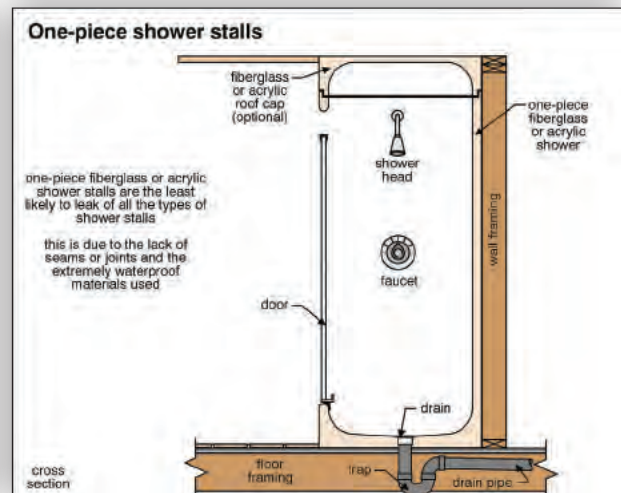
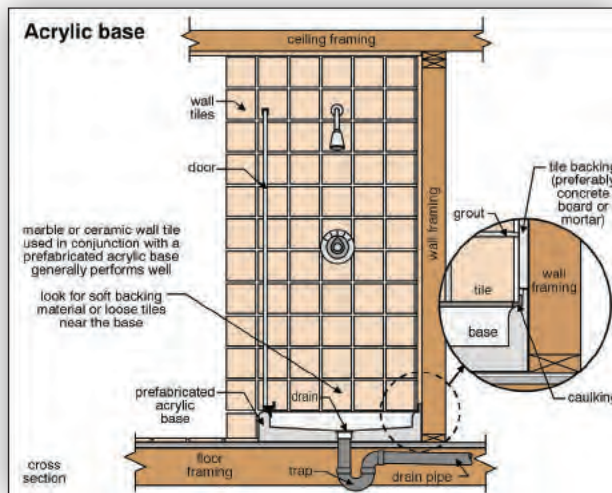
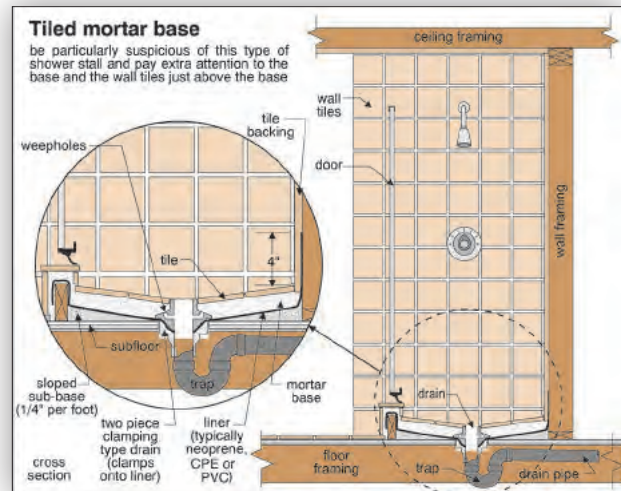

**RISK OF CONCEALED DAMAGE** There is often considerable concealed damage around and below bathtubs and showers that cannot be identified until things are pulled apart.

**RUSTED METAL SHOWER STALL** These low-quality shower stalls are often deteriorated by rust. This can result in leakage and water damage to adjacent house components.

### 3.10 Whirlpool Baths

**DESCRIPTION** A whirlpool bath is essentially a conventional bathtub with a circulating pump, supply jets and a return intake. Whirlpool baths can be very large, and contain a great deal of water when filled. In some cases, the floor structure below has to be strengthened to carry the load.

**GFCI** The electric supply to the whirlpool should be protected by a ground fault circuit interrupter. This is a special, highly sensitive device that will shut off the electricity in the event of a very small electrical fault. This additional safety is important where water and electricity come together.

**SERVICE ACCESS** A readily accessible service door to work on the pump and motor should be provided. Where this is not available, repairs will be more expensive.

**LARGER WATER HEATER** Larger whirlpools may require larger water heaters to ensure the tub can be filled with hot water. Some manufacturers recommend water temperatures not exceed 104°F, to avoid discoloration of the acrylic surface.

**CIRCULATION SYSTEM** The circulation pipes and pump should be arranged to drain after use. We don't want water to accumulate and promote concealed growth of bacteria, etc.

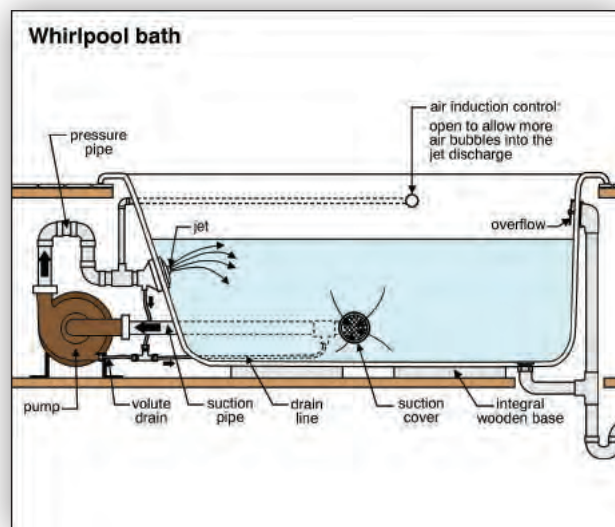
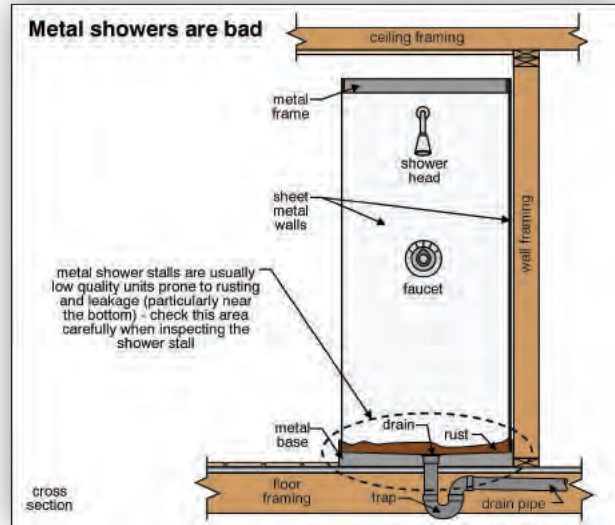

## Common Problems with Whirlpool Tubs

- PUMP AND MOTOR PROBLEMS** Problems may develop with the electric motor or the pump mechanism. If the system does not respond to the operating controls, a service technician may be needed. While it cannot be determined during an home inspection, standing water should not remain in the pump or piping system to avoid bacteria growth and health issues.
- LEAK/ACCESS ISSUES** Leaks or obstructions in the piping lines around the tub can appear, and may be difficult to access and repair. Connection points of the piping to the tub may be potential leakage areas as well.
- ELECTRICAL SUPPLY – NO GFCI** Ground fault circuit interrupters should be installed where missing.

### 3.11 Bidets

**DESCRIPTION** Bidets are complex plumbing fixtures that are susceptible to cross connections. As a result, a vacuum breaker is provided at the supply piping connection to a bidet. This prevents waste water from flowing back into the supply water.

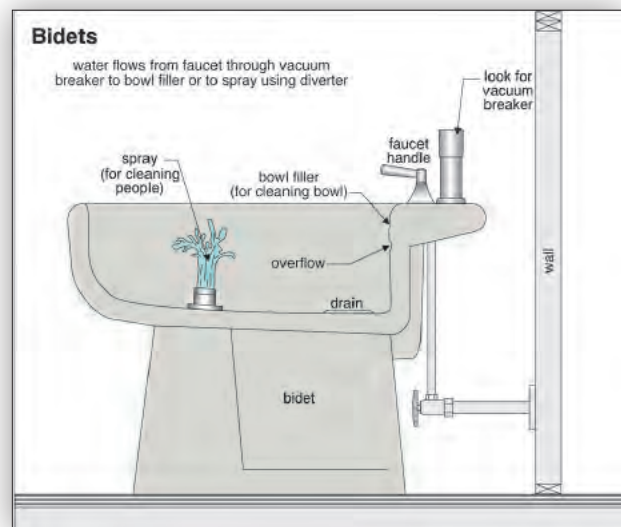

## Common Problems with Bidets

- CRACKS/LEAKS/ CLOGS/VALVE ISSUES** Most bidets are china, and are subject to cracking or leakage. In areas of hard water, the small jets of a bidet can become clogged. Control valves and diverters may leak or break.

### 3.12 Bathroom Fans

- DESCRIPTION** Exhaust fans are recommended in all bathrooms, and are more important where a bathroom does not have an operable window.
- DISCHARGE OUTSIDE** The fan should discharge directly to the building exterior. In many cases, the fan terminates inside the house or roof space. This can add considerable moisture to a house, leading to condensation and rot problems.
- CAPACITY** The exhaust fan should provide at least 12 air changes per hour. That means it should replace all the air in the room every 5 minutes. For example, in a bathroom that is 320 cubic feet (five feet by eight feet by eight feet high) the exhaust fan should have a capability of more than 64 cfm (cubic feet per minute).

#### Common Problems with Bathroom Fans

- MISSING** The concentration of moisture in a bathroom where showers are used can lead to premature failure of interior finishes such as paint and wallpaper, and result in mildew and rot in concealed areas.
- NOISY** Lower quality bathroom fans are noisier than better quality fans. The fan may be operated by a separate switch, or by the room light switch. Timers on bathroom fans are useful, so the fan can run for a few minutes after a person leaves the bathroom to get rid of the accumulated moisture.
- INOPERATIVE** Many bathroom fans are inoperative because the motor or fan mechanism has failed. Some occupants disconnect the fan, irritated by the noise.
- NO DUCT INSULATION** Where the exhaust fan ductwork passes through unheated spaces such as attics, it should be insulated to prevent condensation.
- POOR TERMINATION POINTS** Exhaust fans should never discharge into attics, roof spaces or chimneys. Ductwork running through the attic should be insulated to prevent condensation inside the duct.

### 3.13 Kitchen Fans

- DESCRIPTION** The kitchen fan may discharge outside, or may simply re-circulate the air into the kitchen after passing it through a charcoal filter. Most fans that discharge outside have some sort of filter. In either case, the filters should be cleaned and/or replaced, following the manufacturer's recommendations.
- DOWN-DRAFT** Some cooktops have built-in fans with down draft that exhaust air from the cooktop area. On some appliances, these fans are of modest capacity, and the fan performance may be weak where the exhaust ductwork to the exterior is lengthy or contains several bends.

#### Common Problems with Kitchen Fans

- NO DUCT INSULATION** Exhaust fan ductwork passing through unheated areas such as attics should be insulated to prevent condensation.
- DISCHARGE INTO CHIMNEY** Kitchen fans should never discharge into chimneys.
- INOPERATIVE** An inoperative kitchen fan is usually the result of an interruption in the electrical supply, or failure of the electric motor. The fan itself can be jammed or the bearings may have failed.
- OVERSIZED FANS** Kitchen fans may be so powerful that they cause furnaces and water heaters to backdraft, drawing dangerous combustion products into the home.